



TOOTH

BIG-E Electric Cylinders

Section 1: Force "F" Series 8500 lbs Continuous [EF]

Section 2: Motorized "M" Series 650 lbs Continuous [EM]
(Stepper & Brushless Options & Drives)



Other Products



Linear Actuators | Ball Screws | Gearboxes | Lifts | Systems



fangOPEN & fangMAX Precision Gear Rack Guided Actuators

And

FINGLIDE Guided Ball Screw Actuators



Servo & Industrial Gearboxes

Fangtooth will tackle any solution by making a custom to fit your exact requirement



CALL TODAY

Multi-Axis Systems

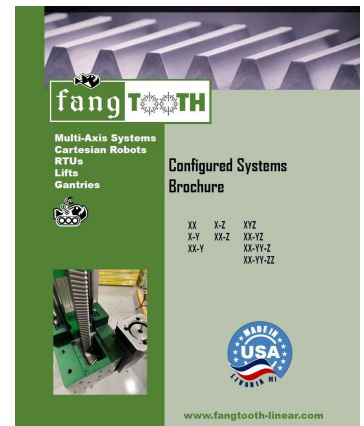

BIG "E" Force F-Series ELECTRIC CYLINDERS

The BIG E-F Series is suitable for the most extreme workloads or in situations where heavy-duty operation is required with a high dynamic load over time.

The profile has a reinforced structure and the driving technology consists in customized sphere recirculation screws, to achieve high dynamic loads offering optimal speed performances thanks to the various step options.

They are ISO 15552 compatible, can be powered by Brushless or Stepper motors, which can also be coupled to gearboxes in order to take up less space and provide a comprehensive solution.

They can include the **AV** device which gives continuous feedback on operation under standard conditions, warning in advance about any maintenance needs.

The EF 150 version has a Steel structure.



EF50

EF63

EF80

EF100

EF125

EF150

	mm	65 mm	75 mm	95 mm	115 mm	135 mm	165 mm
Flange Size	mm	65 mm	75 mm	95 mm	115 mm	135 mm	165 mm
Diameter / Step Screw	mm	20/5-10-20	25/5-10-25	32/5-10-32	40/5-10-40	50/10	63/10-16-20
Dynamic load	kN	14,6-11-13,4	19,8-16-15,1	25,9-29,8-22,7	23,9-60,4-44,4	76,9	87,9-190-141,9
Axial force 2000km	kN	1,98-1,88-2,89	2,69-2,74-3,50	3,52-5,1-5,72	3,24-10,33-12,0	13,15	15-38-30,57
Maximum screw speed	rpm	4500	4500	4062	3250	2600	2063
Maximum axial speed	mm/s	1500	1875	2166	2167	433	688
Useful Ride* (Non standard available under request)	mm	50-500	50-600	50-800	50-800	50-1000	50-500



INSPIRE . GREAT . AUTOMATION

www.fang2th.com - 11970 Mayfield - Livonia, MI 48150

BIG "E" Force F-Series ELECTRIC CYLINDERS

FORCE (kN)

Force Vs. Life expressed in km (based at 500 rpm)

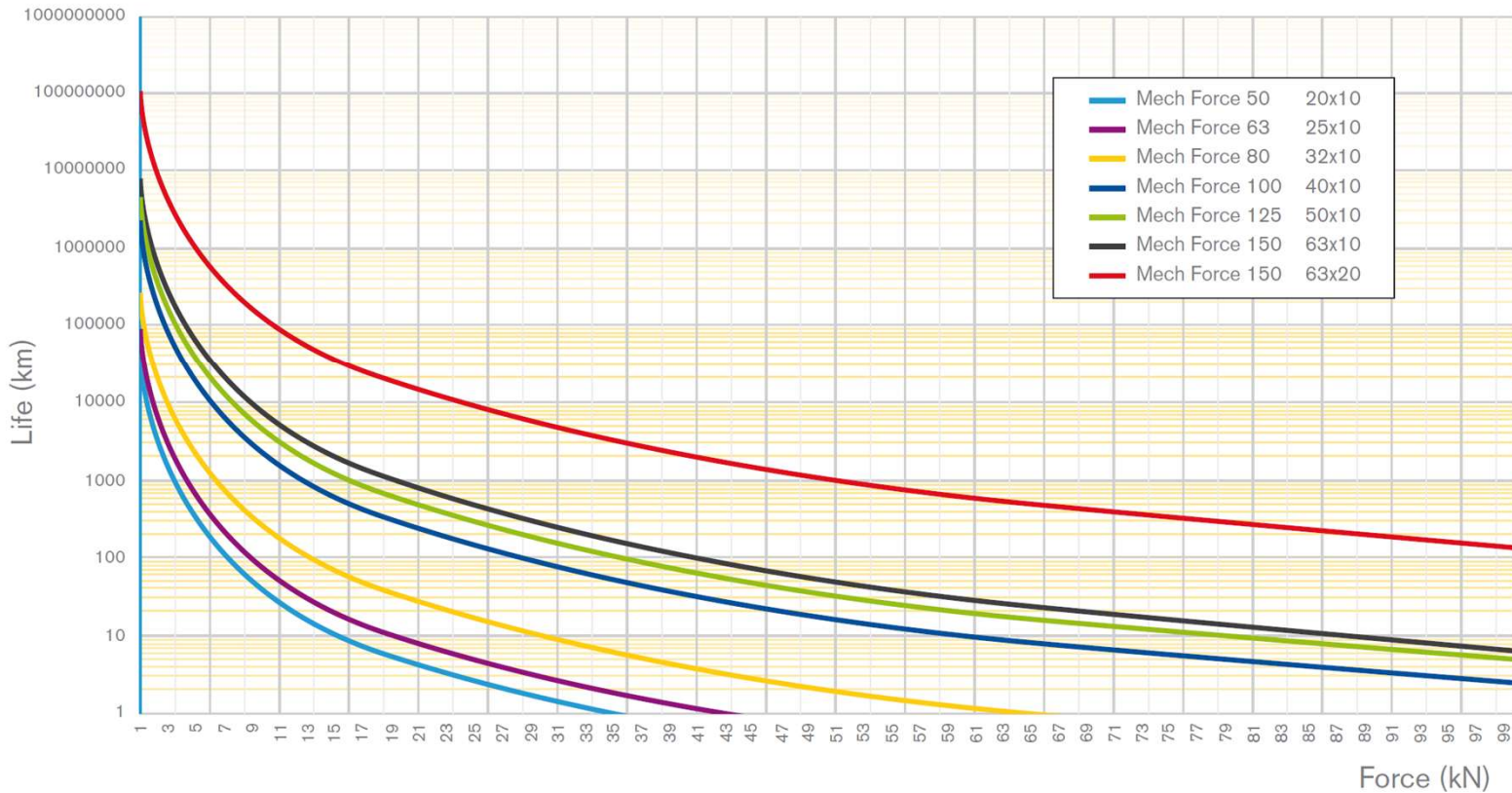

The tables in figure show the operational performance levels in km as a function of the loads applied in kNewton (at a speed of 500 rpm).

The tables are merely indicative: we always recommend sizing depending on the work cycle, speed and load applied.



BIG "E" Force F-Series ELECTRIC CYLINDERS

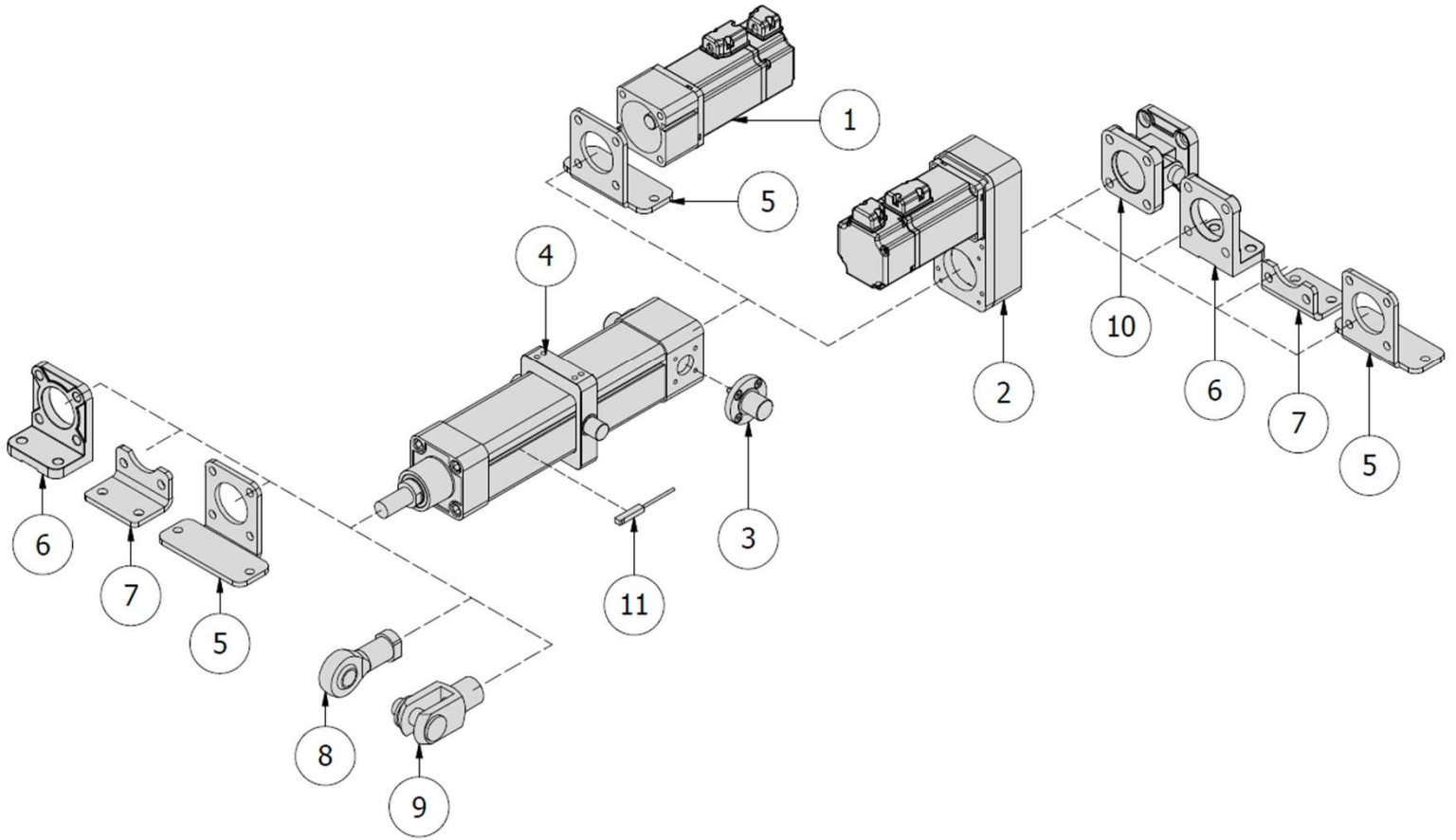

ACCESSORIES

	DESCRIPTIONS
1	Direct drive Kit
2	Parallel Drive Kit
3	Lateral PIN kit
4	Lateral flange support for lateral Kit
5	wider Lateral flange support Kit
6	flange support Kit
7	Lower flange support Kit
8	Clevis rod end
9	Fork rod end
10	Backward joint swinging kit
11	effect hall sensor
	Available Gearbox 3-4-5-7-10-16-20



INSPIRE . GREAT . AUTOMATION

www.fang2th.com - 11970 Mayfield - Livonia, MI 48150

BIG "E" Force F-Series ELECTRIC CYLINDERS

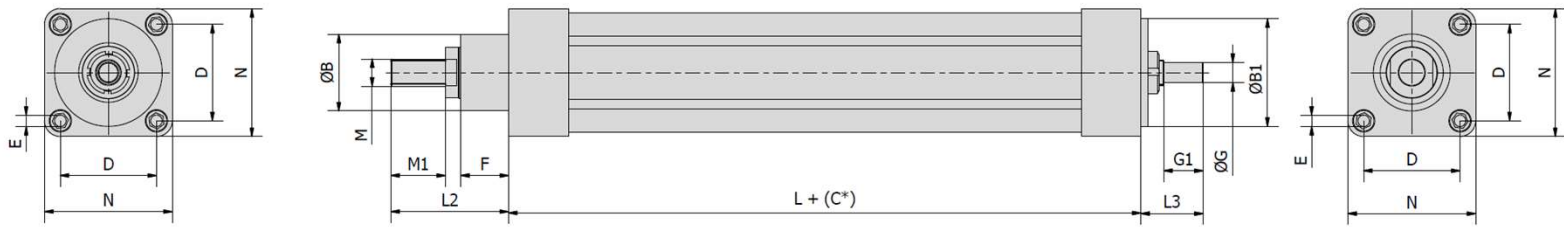

EF50

EF63

EF80

EF100

EF125

EF150

Lead screw	mm	20x5-10-20	25x5-10-25	32x5-10-20-32	40x5-10-20-40	50x5-10-40	63x10-16-20
ØB	mm	40	45	55	70	90	90
ØB1	mm	50	63	80	100	125	150
D	mm	46,5	56,5	72	89	Ø130	Ø130
E	mm	N°4 M8x18	N°4 M8x18	N°4 M10x20	N°4 M10x20	N°8 M10x25	N°8 M16x30
ØG	mm	3	3	3	3	3	3
L	mm	Ø12 h8	Ø14 h8	Ø17 h8	Ø24 h8	Ø32 h8	Ø32 h8
L2	mm	24,5	27	31	40,5	48	50
L3	mm	173	182	228	285	300	438
M	mm	45	55	60	70	105	95
M1	mm	34	36,4	40	52,6	61	64
N	mm	M16x1,5	M20x1,5	M20x1,5	M27x2	M30x2	M36x3
M1	mm	32	40	40	50	60	60
N	mm	65	75	95	115	135	165



INSPIRE . GREAT . AUTOMATION

www.fang2th.com - 11970 Mayfield - Livonia, MI 48150

BIG "E" Motorized M-Series ELECTRIC CYLINDERS

Highly reliable and widespread cylinders, a consolidated product with an excellent price-performance ratio.

They are available on four sizes, **25 - 32 - 50 - 63**, using sphere recirculation screw movement, and are equipped with an anti-rotation device.

They are ISO 15552 compatible.

They can be powered using Stepper or Brushless motors, also with closed-ring control.

Motor power may be direct or delayed.



EM25

EM32

EM50

EM63

	mm	32 mm	47 mm	65 mm	75 mm
Flange Size	mm	32 mm	47 mm	65 mm	75 mm
Diameter / Step Screw	mm	10/3-10	12/5-10	16/5-10-16	20/5-10-20
Dynamic load	kN	2,8-2,5	5,14-3,90	10,49-11,81-8,33	14,6-11,0-13,4
Axial force 2000km	kN	0,32-0,43	0,69-0,67	1,42-2,02-1,67	1,98-1,88-2,89
Maximum screw speed	rpm	4500	4500	4500	4500
Maximum axial speed	mm/s	750	750	1200	1500
Useful Ride* (Non standard available under request)	mm	50-300	50-400	50-500	50-500



INSPIRE . GREAT . AUTOMATION

www.fang2th.com - 11970 Mayfield - Livonia, MI 48150

BIG "E" Motorized M-Series ELECTRIC CYLINDERS DRIVES & DIAGNOSTICS INDUSTRY 4.0

Motors and Drives	I/O	CANopen	Ethercat	Profinet	
Drive AW EZI	X	na	optional	na	Stepper (Nema xx)
Drive AW ECMA	X	X	X	na	na
Drive AW ServoOne	X	X	X	X	na
Encoder	Incremental				Sensorless / Optional
Easy Software	Move Modelling				Option
AwareVu	3D vibration Diagnostic Ind. 4.0				Optional

All cylinders in the Mech series can be fitted with **Stepper** or **Brushless** motors.

The **Stepper** power system includes the possibility of encoder or **sensorless** control, in order to make the cylinder more compact and economical, always guaranteeing precise positioning thanks to a technology which detects position based on electric operation parameters.

With **Brushless** motors very high axial speeds can be achieved, always with the utmost precision, thanks to a wide range of available encoders.

It is based on a full-closed loop control system, with **auto notch filter** which prevents vibrations also at high productivity levels to reduce noise during operation. The 17-bit encoder guarantees high positioning precision, allowing for a 0.01 mm precision.

If the cylinders need to be used in coordination on several axes (for example in TRIPOD- Simulator systems), as an option, we offer a **four-axis** driver with **TRIO software**, in order to allow for advanced motion interpolation.

This axial system control may include our EZI – ECMA -ServoOne drivers, which can all be integrated in a single chassis.

The integrated **E-Cam** connection allows for easy synchronization of motion and positioning with cameras.

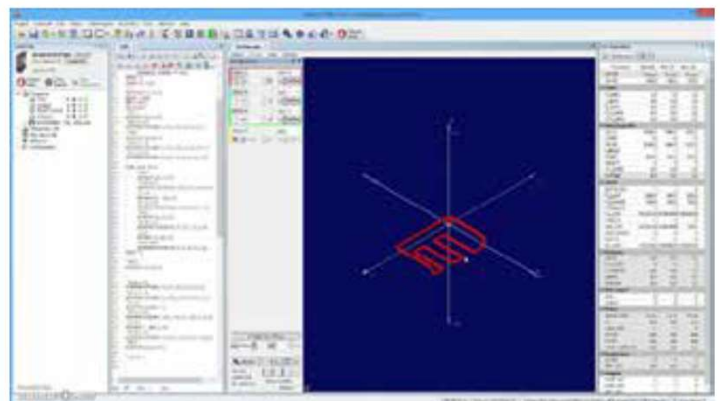

BIG "E" Motorized M-Series ELECTRIC CYLINDERS DRIVES & DIAGNOSTICS INDUSTRY 4.0

For basic applications, Fangtooth has a control software system called Easy which can be installed on a standard PC or Tablet and connected via a USB or Serial interface to the control electronics. The following figure illustrates the main menu of the Easy software.

It is possible to set as many as 64 positions, each of them characterized by adjustable speed and acceleration.

Positioning data can be defined in an absolute or relative way with regard to the current location.

The command selection for the various positions (in succession or random) makes it possible to simulate automated operation of the actuator.

If this command is entered, the actuator moves to the required position and a graphical indication is given of the position reached.

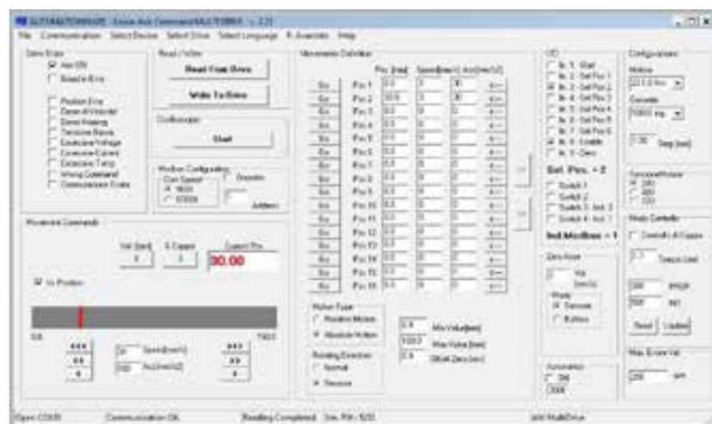

BIG "E" Motorized M-Series ELECTRIC CYLINDERS

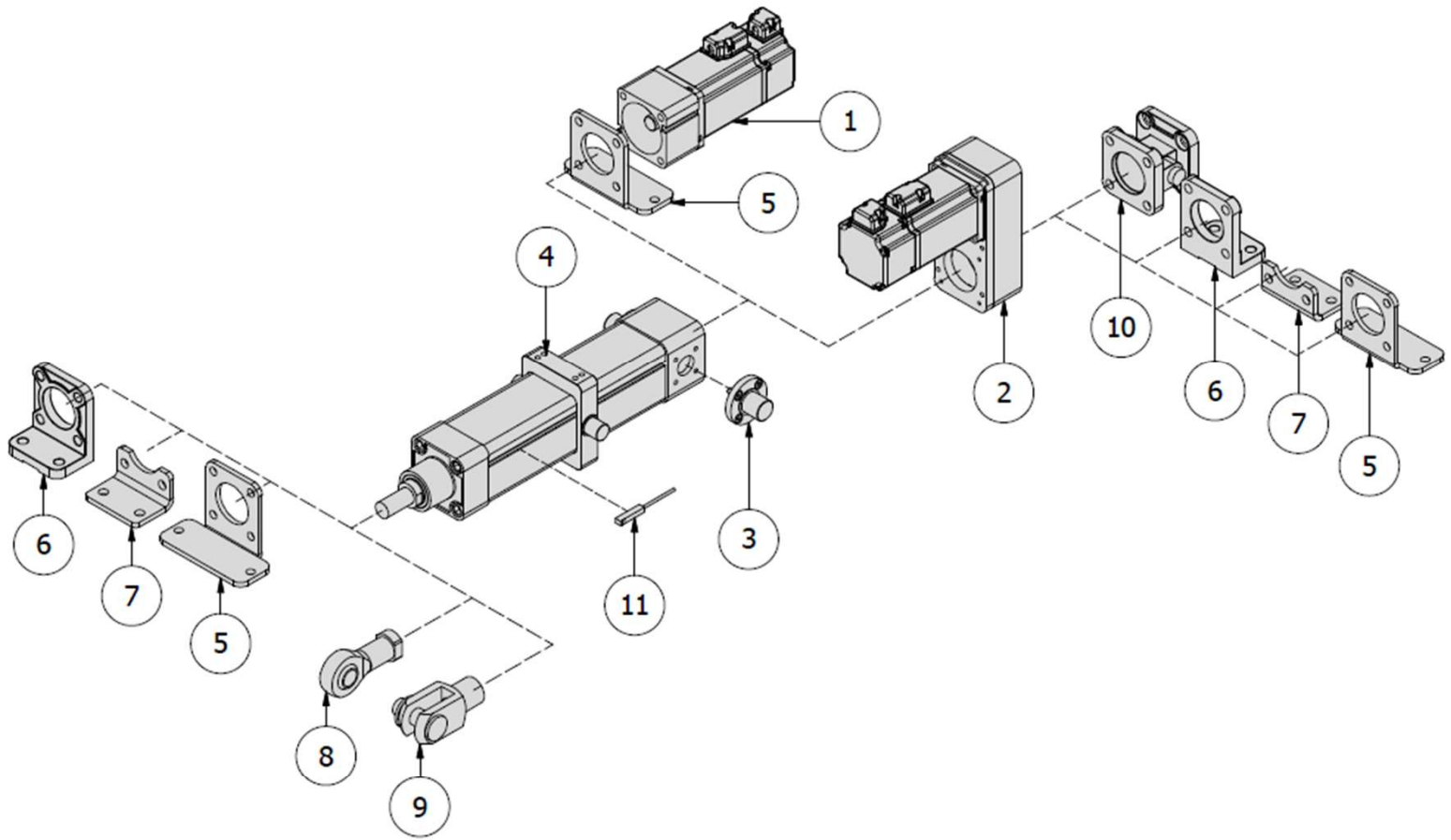

ACCESSORIES

POSITION	DESCRIPTIONS
1	Direct drive Kit
2	Parallel Drive Kit
3	Lateral PIN kit
4	Lateral flange support for lateral Kit
5	wider Lateral flange support Kit
6	flange support Kit
7	Lower flange support Kit
8	Clevis rod end
9	Fork rod end
10	Backward joint swinging kit
11	effect hall sensor
Available Gearbox 3-4-5-7-10-16-20	



INSPIRE . GREAT . AUTOMATION

www.fang2th.com - 11970 Mayfield - Livonia, MI 48150

BIG "E" Motorized M-Series ELECTRIC CYLINDERS

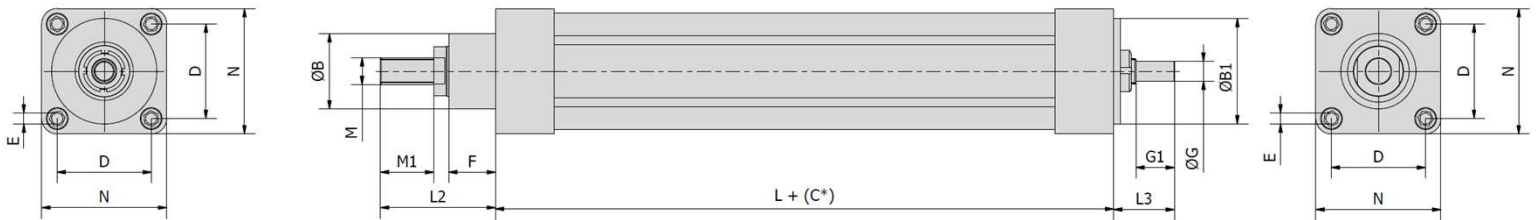

EM25

EM32

EM50

EM63

Lead screw	mm	12x5-10	12x5-10	16x5-10-16	20x5-10-20
ØB	mm	-	30	40	45
ØB1	mm	22	32	50	63
D	mm	Ø26	32,5	46,5	56,5
E	mm	N°4 M3x5	N°4 M6x18	N°4 M8x15	N°4 M8x15
ØG	mm	-	20	28	28
L	mm	Ø6 h8	Ø8 h8	Ø10 h8	Ø12 h8
L2	mm	12,5	16,5	16	23,1
L3	mm	97,3	129	134	171
M	mm	24	48	41	41
M1	mm	20	25,5	27,5	36,5
N	mm	M8	M10x1,25	M16x1,5	M16x1,5
M1	mm	20	20	32	32
N	mm	32	47	65	75



INSPIRE . GREAT . AUTOMATION

www.fang2th.com - 11970 Mayfield - Livonia, MI 48150



SECTION 1: APPLICABILITY

1.1 These terms & conditions (the "Terms and Conditions") of sale are applicable to all quotations for the sale or orders for the purchase of all equipment or goods (the "Products") made by or for Fangtooth Inc 11970 Mayfield St. Livonia MI 48150 ("Company".)

1.2 Unless otherwise agreed, written quotations are valid for 30 days from the date of quotation. All price lists and discounts are subject to change without notice.

1.3 All orders placed by the Buyer are subject to written acceptance by the Company. No contract between Buyer and Company shall exist prior to the time of such acceptance by the Company.

1.4 These Terms & Conditions supersede all prior written terms, understandings, purchase orders, assurances and offers. Company shall not be deemed to have waived these Terms & Conditions if it fails to object to the conditions appearing in or attached to a purchase order issued by Buyer. Buyer's acceptance of the Products or services furnished by the Company shall constitute its acceptance of these Terms & Conditions.

SECTION 2: PRICE & SHIPPING DATES

2.1 All orders must be bona fide commitments showing a complete description of equipment, quantity, price & shipping dates required by the Buyer.

2.2 Timely performance by Company is contingent upon Buyer supplying to Company, when applicable, all required technical information and data, including drawing approvals, and all required commercial documentation. Shipping dates are subject to final confirmation or change by Company and are based on prompt receipt of all necessary information regarding the order. Unless otherwise indicated, all delivery dates specified by the Company are estimated time frames and time is not of the essence in Company's performance of the sale of the Products.

2.3 If shipment is delayed for thirty (30) days or more from the delivery date accepted by the Company for reasons attributable to the Buyer and provided that the Buyer shall have no other liability to the Company in respect of such delay, the reasonable direct costs of putting the Products into storage at a facility off-site of Company's premises until such times as they are shipped (or delivered) shall be the to the Buyer's account and at Buyer's sole risk.

SECTION 3: PAYMENT

Terms of payment are net 30 days from the date of invoice unless otherwise agreed in writing. Late payments may be subject to interest on the unpaid balance at the greater of 2% per month or the maximum rate permitted by law. No deductions or set-offs are to be made by Buyer from amounts due unless specifically authorized by the Company in writing. If in the judgment of the Company, the financial condition of Buyer at any time does not justify continuance of production or shipment on the terms of payment specified, the Company may require full or partial payment in advance.

SECTION 4: TAXES

The Company's prices do not include sales, use, excise taxes, tariffs, duties or value added or similar taxes or fees. The Company will add such taxes or fees to the invoice unless the Buyer provides Company with tax-exempt certificate acceptable to the applicable taxing authorities or arranges payment of such taxes or fees directly by the Buyer.

SECTION 5: WARRANTY

5.1 NEW PRODUCT – Company warrants the Products shall be free of defects in material and workmanship and meet the Product specifications for a period from the date of shipment as specified below.

5.1.a FANGTOOTH MAX straddle mounted pinion systems – 3 years.

5.1.b FANGTOOTH OPEN cantilevered pinion systems – 2 years.

5.1.c FANGTOOTH Any products not specified as standard including any units with non-standard coatings for corrosion claims – 1 year.

5.1.d FANGBOT integrated systems – FANGTOOTH MAX integrated into larger systems will carry the full 3 year warranty. FANGTOOTH OPEN integrated into larger systems will carry the full 2 year warranty. Custom (non-standard) engineered products within the larger systems or any other non-standard FANGTOOTH products will be warranties for 18 months.

5.2 Notwithstanding the warranty periods listed above, the warranty on normal wear items such as oil seals is limited to one year. The warranties of gearboxes, motors, brakes, couplings, linear rail, linear bearings, gear rack and pinion and all other add on items shall be the warranties provided by, and shall be the responsibility of, the original equipment manufacturer. The Company is not responsible for and does not warrant (a) equipment, components and/or material furnished by the Buyer; (b) the sufficiency of functionality of any design specifications furnished by the Buyer; nor shall Company be liable for defects or damages arising from the foregoing. Notwithstanding any other provision in these Terms and Conditions, none of the warranties given by the Company shall apply to products manufactured by others and sold by the Company. Buyer will at its own expense arrange for any dismantling and reassembly of any goods and equipment and the provision of all equipment (including without limitation lifting equipment and crane-age) to the extent that this is necessary to remedy the defect or facilitate re-performance of service.

Unless otherwise agreed, necessary transport of the Products and/or parts thereof to and from Company in connection with the remedying of defects will be at the risk and expense of the Buyer. Buyer will follow Company's instructions regarding such transport.

Unless otherwise agreed, Buyer will bear any additional costs which Company incurs as a result of the Products being located in a place other than the place of delivery.

Defective parts which have been replaced will be made available to Company and will be its property.

5.3 Any claims under this warranty must be made in writing to the Company at the address set forth above (or by email) within thirty (30) days of the discovery thereof. The

Company's obligation under this warranty shall be limited to the repair or replacement, at the Company's option, of the Product, or any part thereof, when the Company has determined the Product is not warranted; any Product or parts repaired or replaced pursuant to the warranty will be warranted for the remainder of the original warranty period. The Company shall not be responsible for any claims which the Company determines are due to improper installation, operation above rated capacity, exceeds L10 life cycles, operation at extreme conditions, normal wear and tear, accident, or because the Product has been used, adjusted, altered, handled, maintained, repaired or stored other than as directed by the Company.

5.4 This warranty shall not apply in the event of defects caused by: (i) physical abuse of the Products or any component, or acts of vandalism by any persons other than Company; (ii) alterations, modifications, additions, or repairs made during the applicable warranty period by anyone other than Company, and its authorized employees, agents or subcontractors; (iii) accidents or damage resulting from fire, water, wind, hail, lightning, electrical surge or failure, earthquake, theft or similar causes not caused by the sole negligence of Company; (iv) damage as a result of corrosion or other damage caused by Buyer's failure to protect and maintain the Products in accordance with Company's written instructions and warnings; or (v) design specifications furnished by Buyer.

5.5 Buyer shall not rely upon Company's skill or judgement or furnish Products for any particular purpose beyond the specific express warranties provided herein. Buyer has the responsibility to determine whether the Products and specifications are fit for buyer's intended purpose. Company does not warrant the Products will comply with the requirements or any safety code or regulations, or with any environmental or other law or regulation. Buyer is responsible for the safe and lawful operation and use of the Products.

5.9 THE FOREGOING WARRANTIES ARE THE SOLE WARRANTIES PROVIDED BY COMPANY FOR THE PRODUCTS AND ARE IN LIEU OF ALL OTHER WARRANTIES, EXPRESS OR IMPLIED, ALL OF WHICH ARE HEREBY DISCLAIMED AND EXCLUDED BY MERCHANTABILITY OR FITNESS FOR A PARTICULAR PURPOSE OR USE. BUYER AGREES THAT ITS SOLE AND EXCLUSIVE REMEDY AGAINST COMPANY WILL BE LIMITED TO THE REPAIR AND REPLACEMENT OF NONCONFORMING OR DEFECTIVE PRODUCTS PROVIDED COMPANY IS PROMPTLY NOTIFIED IN WRITING OF ANY DEFECT. THIS EXCLUSIVE REMEDY WILL NOT BE DEEMED TO HAVE FAILED OF ITS ESSENTIAL PURPOSE SO LONG AS COMPANY IS WILLING TO REPAIR OR REPLACE THE NONCONFORMING OR DEFECTIVE PRODUCTS.

SECTION 6: OWNERSHIP OF INTELLECTUAL PROPERTY

Company retains ownership and all rights to its intellectual property. Buyer shall have no rights to Company's intellectual property. Any intellectual property developed by Company and arising in connection with the supply of Products hereunder shall be deemed property of Company, and Company shall have exclusive rights to the use and ownership of such intellectual property.

SECTION 7: THIRD PARTY INTELLECTUAL PROPERTY CLAIMS

Company shall pay costs and damages finally awarded in any suit against Buyer by a third party to the extent based upon a finding that the design or construction of the Products as furnished infringes a patent or other third party intellectual property rights (except infringement occurring as a result of incorporating a design or modification at Buyer's request), provided that Buyer promptly notifies Company of any charge of infringement, and Company is given the right at its expense to settle such charge and to defend or control the defense of any suit based upon such charge. Company shall have no obligation hereunder with respect to claims, suits or proceedings, resulting from or related to, in whole or in part, (i) the use of software or software documentation, (ii) compliance with Buyer's specifications, (iii) the combination with other products, or modification of, the Products after delivery by Company, or (iv) the use of the Products, or any part thereof, in the practice of a process. THIS SECTION SETS FORTH COMPANY'S ENTIRE LIABILITY WITH RESPECT TO PATENTS OR OTHER INFRINGEMENTS OF INTELLECTUAL PROPERTY.

SECTION 8: RETURN OF PRODUCTS

In the event that the Buyer does not accept the Products, the Buyer must apply for authorization from the Company before returning the Products to the Company for credit. The Company will advise the Buyer of the credit to be allowed and necessary restocking charges on the unused material, subject to the Company's inspection and acceptance when received. No material should be returned to the Company except upon receipt of written authorization. In addition to the usual restocking charges, the Buyer must pay the actual transportation expense of the Company, plus all return transportation costs. Motors and specially designed parts will not be accepted for return or credit.

SECTION 9: DELIVERY, TITLE AND RISK OF LOSS

The Products will be delivered Ex Works – Fangtooth Inc's facility (in accordance with Incoterms 2010) unless otherwise agreed in writing by Company. The Buyer will be responsible for making all shipping arrangements, and Buyer will provide sufficient notice and details of such arrangements to allow Company to prepare the Products for delivery. Title and risk of loss will remain with Company and not pass to Buyer until delivery to the Incoterm delivery point.

SECTION 10: FORCE MAJEURE

Company will not be deemed to be in default or otherwise responsible for delays or failures in performance resulting from acts of God: acts of war, or civil disturbance, terrorism, epidemics, governmental action or inaction, fires, floods, earthquakes, tornadoes, or other events beyond Company's reasonable control (a "Force majeure Event"). A Force Majeure Event affecting Company's vendors shall also be deemed as a Force Majeure Event for the Company, provided that the Company shall use commercially reasonable efforts to mitigate any delays caused by its vendor's Force Majeure situation. Company shall in such instances give notice of the non-performance (including its anticipated duration) to the Customer promptly after becoming aware that it has occurred or will occur. In no event shall lack of finances or ability to pay as a result of the financial condition of either party be considered a Force Majeure Event.

SECTION 11: CANCELLATION

Upon written acceptance of an order by the Company, Buyer may not cancel or terminate for convenience, or direct suspension of manufacture, except with Company's written consent and then only upon terms that will compensate Company for its engineering, fabrication and purchasing charges and any other costs relating to such cancellation, termination, or suspension, plus a reasonable amount for profit and overhead.

SECTION 12: ETHICAL BUSINESS PRACTICES

Company requires manufacturing and business practices that are compliant with all applicable laws and regulations, including, the need to conduct all transactions in compliance with ethical business practices. Both the Company and the Buyer agree that neither of them nor their employees, agents, representatives, or other intermediaries will engage in any activity that may be construed to be in violation of their respective codes of ethical business practices or applicable law. Buyer acknowledges and agrees that it shall not, in regards to the sale or resale of the Company's products, make any payment or transfer of value to any third party (including through any or multiple intermediaries) that would cause either the Buyer, Company or any of Company's affiliates to violate either the U.S. Foreign Corrupt Practices Act or any other applicable anti-corruption laws. Buyer shall indemnify and hold Company and Company's affiliates harmless in the even of any breach of this paragraph by buyer or any of its intermediaries.

SECTION 13: LIMITATION OF LIABILITY

NEITHER COMPANY AND ITS AFFILIATES AND THEIR RESPECTIVE OFFICERS, DIRECTORS, EMPLOYEES, AGENTS, INSURERS AND ATTORNEYS SHALL BE LIABLE, WHETHER IN CONTRACT, WARRANTY, FAILURE OF A REMEDY TO ACHIEVE ITS INTENDED OR ESSENTIAL PURPOSES, TORT (INCLUDING LOSS OF USE, REVENUE OR PROFIT, OR FOR COSTS OF CAPITAL OR OF SUBSTITUTE USE OR PERFORMANCE, OR FOR INDIRECT, SPECIAL, LIQUIDATED, INCIDENTAL OR CONSEQUENTIAL DAMAGES, OR FOR ANY OTHER LOSS OR COST OF SIMILAR TYPE, OR FOR OTHER CLAIMS BY BUYER FOR ANY DAMAGES OR LOSSES. COMPANY'S MAXIMUM LIABILITY FOR ALL CLAIMS AND LOSSES ARISING OUT OF THE MANUFACTURE OR SALE OF THE PRODUCTS SHALL BE THE PRICE CONFIRMED BY THE COMPANY RELATING TO THE INDIVIDUAL SALE TRANSACTION WITH THE BUYER. BUYER AND COMPANY AGREE THAT THE EXCLUSIONS AND LIMITATIONS SET FORTH IN THIS SECTION ARE SEPARATE AND INDEPENDENT FROM ANY REMEDIES WHICH BUYER MAY HAVE HEREUNDER AND SHALL BE GIVEN FULL FORCE AND EFFECT WHETHER OR NOT ANY OR ALL SUCH REMEDIES SHALL BE DEEMED TO HAVE FAILED OF THEIR ESSENTIAL PURPOSE.

SECTION 14: GOVERNING LAW

The terms of the sales of the Products shall be governed and controlled in all respects by the laws of the State of Michigan and all disputes, including interpretation, enforceability, validity, and construction, shall be determined under the law of the State of Michigan without regard to any conflict of law provisions. Any dispute arising between the parties will be finally resolved in the state or federal courts of Michigan. Each party consents to personal jurisdiction in the state and federal courts of the State of Michigan for any all matters related to or arising out of the sale, attempted sale, delivery, warranty, maintenance or use of the Products, and agrees that personal jurisdiction in any such court will be deemed proper. Buyer shall be liable to Company for any attorney fees and costs incurred by Company in enforcing any of its rights hereunder.

SECTION 15: STATUTE OF LIMITATIONS

To the extent permitted by applicable law, any lawsuit for breach of contract, including breach of warranty, arising out of the transactions covered by this Purchase Order, must be commenced not later than twelve (12) months from the date the cause of action accrued.

SECTION 16: CHANGES IN LAWS AND REGULATIONS

Company's prices and timely performance are based on all applicable laws, rules, regulations, orders, codes, standards or requirements of governmental authorities effective on the date of Company's proposal. Any applicable change to the forgoing shall entitle Company to an equitable adjustment in the prices and time of performance.

SECTION 17: COMPLIANCE WITH EXPORT LAWS AND REGULATIONS

Certain Products manufactured by Company, as well as technical data related thereto, may be subject to export licensing controls under the U.S. Export Administration Regulations and/or the U.S. International Traffic in Arms Regulations, which require licensing for and/or prohibit the export or diversion of the Company's products to certain countries. If Buyer is responsible for obtaining export approvals. Buyer warrants that it will not assist or participate in any export of the Company's products or related technical data without first obtaining the required export license and will not knowingly assist or participate in any such diversion or other violation of applicable U.S. laws and regulations. If Company is responsible for obtaining export approvals, Buyer shall assist the Company, as necessary, in obtaining such approvals. Buyer shall indemnify and hold the Company and its affiliates harmless from any losses or claims arising out of or related to Buyer's failure to comply with applicable export control laws and regulations.

SECTION 18: COMPLIANCE WITH LAWS

Buyer agrees to comply with all applicable local, state, Federal and Foreign laws, orders, directives, and regulations at any time in effect, including, but not limited to, those found in 41 CFR 60 requiring equal opportunity and affirmative action without regard to race, color, religion, sex, national origin, presence of disability or status as a special disabled veteran or Vietnam era veteran, which specifically incorporated herein by reference. If Buyer fails to comply with the provisions of this paragraph, Company may, by written notice to Buyer, terminate any Order for Buyer's default in addition to exercising any other rights or remedies provided by law.

SECTION 19: RELATIONSHIP OF THE PARTIES

Buyer and Company are independent contractors, and nothing in the contract makes either party the agent or legal representative of the other party for any purpose. Neither party has authority to assume or to create any obligation on behalf of the other party.

SECTION 20: WAIVER

The failure of Company to enforce any right or remedy provided in contract or by law on a particular occasion will not be deemed a waiver of that right or remedy on a subsequent occasion or a waiver of any other right or remedy.

SECTION 21: SEVERABILITY

A finding that any provision in these Terms & Conditions or an accepted purchase order is invalid or unenforceable in any jurisdiction will not affect the validity or enforceability of any other provision of these Terms & Conditions or an accepted purchase order or the validity or enforceability of that provision in any other jurisdiction.

SECTION 22: ASSIGNMENT and DELEGATION

No right or interest in the sale of Products hereunder shall be assigned by the Buyer without written permission of the Company. No delegation of any obligation owed, or the performance of any obligation by the Buyer, shall be made without the written permission of the Company. Any attempted assignment of delegation shall be wholly void and totally ineffective for all purposes unless made in conformity with this section. Company shall have the right to assign its obligations to any affiliate of the Company or any successor to substantially all the business or assets of the Company.

SECTION 23: THIRD PARTY RIGHTS

Notwithstanding any provision of law, no third party (including Buyer's customer) shall have the right to enforce these Terms & Conditions or any other contractual rights against Company or its affiliates.

SECTION 24: HEADINGS

The headings of the various paragraphs of these Terms & Conditions have been inserted for convenient reference only and shall not to any extent have the effect of modifying, amending, or changing the expressed terms and provisions hereof.

SECTION 25: ENTIRE AGREEMENT

These Terms & Conditions, including any attachments hereto, constitutes the entire understanding and agreement between the parties and supersedes any prior oral or written agreements with respect to the subject matter hereof. No course of prior dealings between the and the Buyer, and no usage of the trade shall be relevant to supplement or explain and term used herein. Acceptance or acquiescence in a course of performance rendered hereunder shall not be relevant to determine the meaning of these Terms & Conditions even though the accepting or acquiescing party has knowledge of the performance and opportunity for objection. Whenever a term defined by the Uniform Commercial Code is used herein, the definition contained in the Uniform Commercial Code shall control



Featured Product:

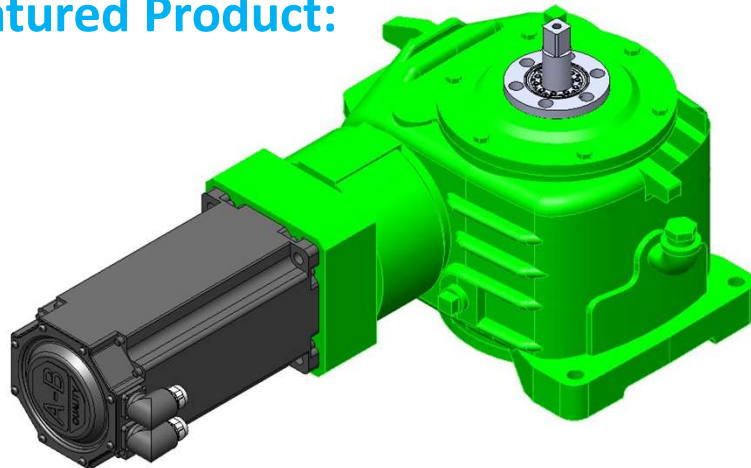

16,681
Pound Max
Lifting
Capacity



Fangtooth Inc.
11790 Mayfield St
Livonia, MI 48150
Ph 248-798-4877

FANGTOOTH INC
IDEAS WITH TEETH
PRECISION MECHANICAL DRIVES
FOR FACTORY AUTOMATION AND
INDUSTRIAL MACHINERY

Guided Rack & Pinion Axis
Gantries / Lifts / Configured Systems
Gearboxes & Couplings
Ball Screw & Belt Drive Assemblies
High Powered Screw Jacks

www.fangtooth-linear.com