

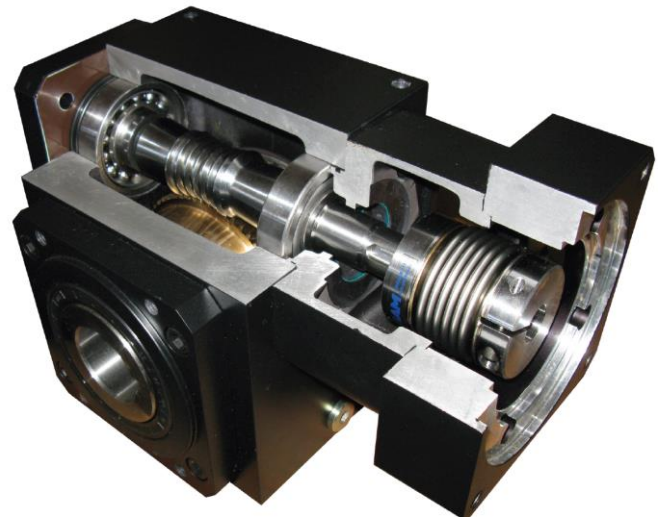

fang TOOTH



High Precision Gearboxes & Industrial Gear Reducers

- + Ratio Boosters
- + Motors
- + BrakeMotors

SERVO WORM GEAR BOXES

Fangtooth
GhostDRIVE **"GhD"**
Series

Fangtooth
IronDRIVE **"FeD"**
Series

Fangtooth
HeavyDRIVE **"HvD"**
Series

NEMA WORM GEAR BOXES

Fangtooth
HeavyDRIVE **"HvD"**
Series

Fangtooth
Conveyor Killer **"CvK"**
Series

"CvK" Interchanges with
Boston Gear Raider
Grove Cobra

Tigear
Omnibox

SPIRAL BEVEL **"SpB"** SERIES



www.fangtooth-linear.com

Other Products

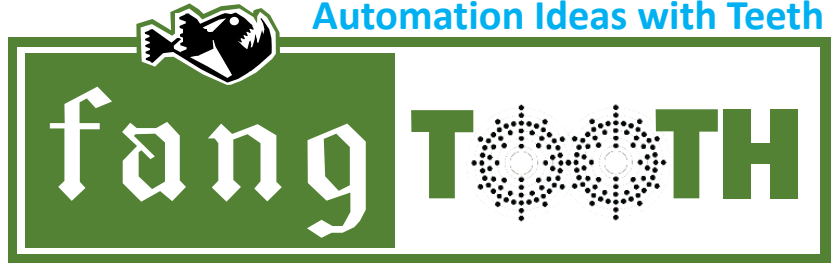

Linear Actuators | Ball Screws | Gearboxes | Lifts | Systems



Ball Screw Assemblies And Linear Actuators

Multi-Axis Systems

We love doing customs

Fangtooth will tackle any solution by making a custom to fit your exact requirement

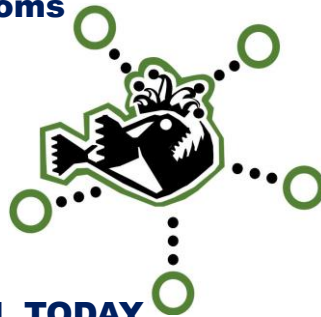

CALL TODAY

High Force Lifting Jacks & Guided Rack

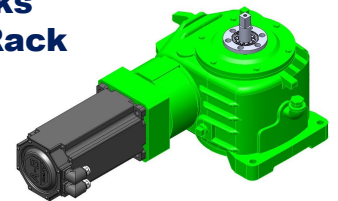

High Precision Gearboxes & Industrial Gear Reducers

CATALOG CONTENTS



SERVO WORM GEAR BOXES

Fangtooth
GhostDRIVE "GhD"
Series [Page 4]

Fangtooth
IronDRIVE "FeD"
Series [Page 11]

Fangtooth
HeavyDRIVE "HvD"
Series [Page 18]

NEMA WORM GEAR BOXES

Fangtooth
HeavyDRIVE "HvD"
Series [Page 18]

Fangtooth
Conveyor Killer "CvK"
Series [Page 46]

Interchanges with
Boston Gear
Grove
Raider
Cobra
Tigear
Omnibox
Ohio

SPIRAL BEVEL "SpB" SERIES [Page 57]

MOTORS [Page 64]

CUSTOM GEARBOXES

...OUR
STRENGTH

- CUSTOM RATIOS
- CUSTOM BORES
- CUSTOM ADAPTERS
- CUSTOM MOUNTING
- CUSTOM SEALS, etc.

Fangtooth will tackle any solution by making a custom to fit your exact requirement



CALL TODAY

INSPIRE . GREAT . AUTOMATION

www.fang2th.com - 11970 Mayfield - Livonia, MI 48150



Steel Housing

For Higher Ratios Fangtooth Offers
 May ways to increase your torque
 Multiplication with double and triple
 gear stages.

Call us today for application support.

Planetary **RATIO boost** “PRb” Series



CUSTOM GEARBOXES

...OUR STRENGTH

- CUSTOM RATIOS
- CUSTOM BORES
- CUSTOM ADAPTERS
- CUSTOM MOUNTING
- CUSTOM SEALS, etc.

Fangtooth will
 tackle any solution
 by making a
 custom to fit your
 exact requirement



CALL TODAY



Servo Worm Gearboxes Ultra Quiet & Ultra Light

Double Enveloping Worm Aluminum Housing

Ask about Self-Locking Ratios

Maintenance Free
Factory filled with synthetic gear oil
No lubrication service throughout unit life
Anodized housing, double oil seals and O-rings provide IP65 protection, ensure worry-free operation and protection against harsh environments

Double Enveloping Worm Gearing
High torque capacity
High efficiency
Quiet and smooth running
Exact ratios 5:1 and 60:1 in a single stage
High torsional rigidity

Three Levels of Precision
Zero Backlash - absolute zero backlash for life
Low Backlash - as low as 3 arcminutes
Standard Backlash - long lasting ruggedness for less demanding applications

Hollow Shaft Standard
Compact mounting saves space
No coupling required saves cost
Zero backlash shrink disc hollow shaft option
Single and double oil extended solid shafts provide mounting flexibility

Easy Motor Mounting
Integrated zero backlash belows coupling provides fast, error-free alignment
Integrated motor flange mounts directly to your servomotor, NEMA motor, or IEC motor

Universal Housing
Compact cube design saves space
Machined pilots on output shaft caps
Universal housing mounts in any orientation
Lightweight aluminum reduces weight

Ghost Drive "GhD" Series

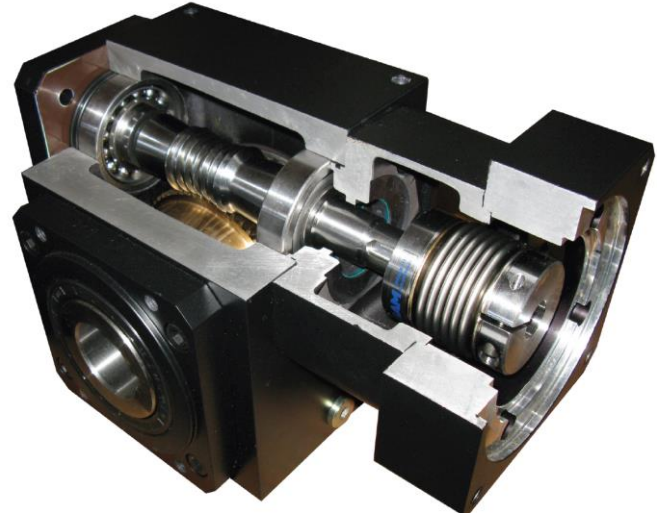

Sizes

GhD38SW
GhD51SW
GhD64SW
GhD76SW
GhD89SW

- **CUSTOM RATIOS**
- **CUSTOM BORES**
- **CUSTOM ADAPTERS**
- **CUSTOM MOUNTING**
- **CUSTOM SEALS, etc.**

Fangtooth will tackle any solution by making a custom to fit your exact requirement



CALL TODAY



Fangtooth GhostDRIVE GhD
Ultra Quiet & Ultra Light
Gearbox Technical Information

www.fangtooth-linear.com

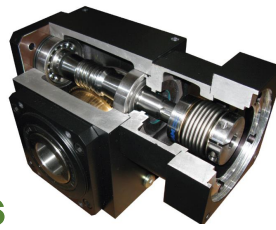

ORDERING CODES

Ghost Drive "GhD" Series

Servo Worm Gearboxes
Ultra Quiet & Ultra Light

Model: GhD038SW-S010Q-012 Z2K/MS2N04

Gearbox Series
GhD – Ghost Drive

Gearbox Size
038 – 38.1mm CD
051 – 50.9mm CD
064 – 63.5mm CD
076 – 76.2mm CD
089 – 88.9mm CD

Gearbox Drive Type
SW – Servo Worm

Gearbox Backlash
S – Standard
L – Low
Z – Zero

Gearbox Ratio

005 – 5:1	020 – 20:1
006 – 6:1	025 – 25:1
007 – 7:1	030 – 30:1
008 – 8:1	040 – 40:1
009 – 9:1	050 – 50:1
010 – 10:1	060 – 60:1
015 – 15:1	

Gearbox Input
SIP – Single Input
DIP – Dual Input
Motor Model – Mounting Kit

Gearbox Output Type
K – Keyed
S – Smooth
D – Shrink Disc
E – End Mount

Gearbox Output Location
HH – Hollow Bore Through
H1 – Hollow Bore "1" side
H2 – Hollow Bore "2" side
ZZ – Solid Shaft, Double Ext
Z1 – Solid Shaft "1" side
Z2 – Solid Shaft "2" side

Gearbox Output Size
– size in 16th of an inch
##M – size in mm

Gearbox Mounting
Q – Standard

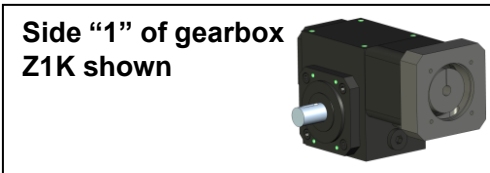

RATINGS

Ghost Drive "GhD" Series

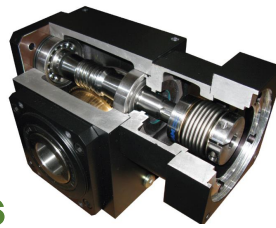

Servo Worm Gearboxes
Ultra Quiet & Ultra Light

	RATIO	EFF%		Ghd038	GhD051	GhD064	GhD076	GhD089
Output Torque ⁽¹⁾ T _{ACCEL}	5	92%	lb.in.	410	800	1470	2430	4250
			Nm	46	90	170	270	480
	6	91%	lb.in.		880	1630	2710	4750
			Nm		99	180	310	540
	7	91%	lb.in.		930	1720	2870	5030
			Nm		110	190	320	570
	8	91%	lb.in.		980	1820	3050	5340
			Nm		110	210	340	600
	9	90%	lb.in.		1000	1850	3140	5480
			Nm		110	210	350	620
	10	90%	lb.in.	520	1020	1900	3240	5650
			Nm	59	120	210	370	640
	15	88%	lb.in.	540	1060	1960	3370	5870
			Nm	61	120	220	380	660
	20	85%	lb.in.	530	1060	1920	3300	5740
			Nm	60	120	220	370	650
	25	84%	lb.in.		1020	1920	3300	5740
			Nm		120	220	370	650
	30 ⁽³⁾	80%	lb.in.	500	990	1840	3160	5510
			Nm	56	110	210	360	620
	40 ⁽³⁾	76%	lb.in.	460	940	1750	3020	5250
			Nm	52	110	200	340	590
	50 ⁽³⁾	73%	lb.in.	460	910	1690	2910	5060
			Nm	52	100	190	330	570
60 ⁽³⁾	70%	lb.in.	420	870	1620	2790	4850	
		Nm	47	100	180	320	550	
Emergency Stop				(3 - Times T _{Run})				
Maximum Radial Load ⁽²⁾			lbs.	700	1500	2000	2500	3500
			N	3110	6670	8890	11110	15560
Maximum Axial Load			lbs.	400	410	420	950	900
			N	1780	1820	1860	4220	4000
Average Lifetime			Hours.	25,000				
Weight			lbs.	9	18	32	56	110
			kg	4.1	8.2	14.5	25.4	49.9
Operating Temperature			°F	(-13 to +210)				
			°C	(-25 to +100)				
Degree of Protection				IP 65				
Lubrication				Synthetic SHC 634 gear oil				
Mounting Position				any				



RATINGS

Ghost Drive "GhD" Series

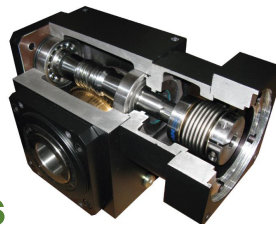

Servo Worm Gearboxes
Ultra Quiet & Ultra Light

RATIO			Ghd038	GhD051	GhD064	GhD076	GhD089	
Moment of Inertia ⁽¹⁾ J_{gear}	5	lb.in. S ² 10 ⁻⁴	11.10	20.40	74.20	127.00	220.00	
		kgcm ²	1.26	2.31	8.38	14.40	24.80	
	6	lb.in. S ² 10 ⁻⁴		18.60	69.20	111.00	180.00	
		kgcm ²		2.10	7.82	12.50	23.30	
	7	lb.in. S ² 10 ⁻⁴		17.50	66.00	100.00	156.00	
		kgcm ²		1.97	7.45	11.30	17.60	
	8	lb.in. S ² 10 ⁻⁴		16.80	64.30	93.90	140.00	
		kgcm ²		1.90	7.26	10.60	15.80	
	9	lb.in. S ² 10 ⁻⁴		16.30	63.00	89.40	129.00	
		kgcm ²		1.84	7.11	10.10	14.60	
	10	lb.in. S ² 10 ⁻⁴		9.66	15.90	62.00	86.20	122.00
		kgcm ²		1.09	1.80	7.00	9.73	13.80
	15	lb.in. S ² 10 ⁻⁴		9.38	15.10	59.80	78.50	104.00
		kgcm ²		1.06	1.71	6.75	8.87	11.70
	20	lb.in. S ² 10 ⁻⁴		9.30	1.48	59.80	78.50	104.00
		kgcm ²		1.05	1.67	6.67	8.57	11.00
	25	lb.in. S ² 10 ⁻⁴			14.70	58.70	74.60	94.40
		kgcm ²			1.66	6.62	8.43	10.70
	30	lb.in. S ² 10 ⁻⁴		9.22	14.60	58.40	74.00	92.70
		kgcm ²		1.04	1.65	6.60	8.35	10.50
	40	lb.in. S ² 10 ⁻⁴		9.20	14.60	58.30	73.30	91.20
		kgcm ²		1.40	1.64	6.58	8.28	10.30
	50	lb.in. S ² 10 ⁻⁴		9.20	14.50	58.20	73.00	90.40
		kgcm ²		1.04	1.64	6.57	8.24	10.20
60	lb.in. S ² 10 ⁻⁴		9.20	14.50	58.10	72.80	90.00	
	kgcm ²		1.04	1.64	6.56	8.22	10.20	
Nominal Backlash	Zero	arcmin.		0	0	0	0	
	Low	arcmin.	8	6	5	4	3	
	Standard	arcmin.	24	15	12	10	10	
Torsional Rigidity		lb.in./min	34	67	155	341	628	
		Nm/min	3.8	7.6	17.5	38.5	71	
Max. cyclic input speed ⁽²⁾ ⁽⁴⁾		rpm	6000	6000	6000	6000	6000	
Max. cyclic input speed ⁽³⁾ ⁽⁴⁾		rpm	4000	4000	4000	4000	4000	



DIMENSION HOLLOW Ghost Drive "GhD" Series

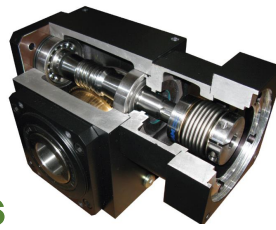

Servo Worm Gearboxes
Ultra Quiet & Ultra Light

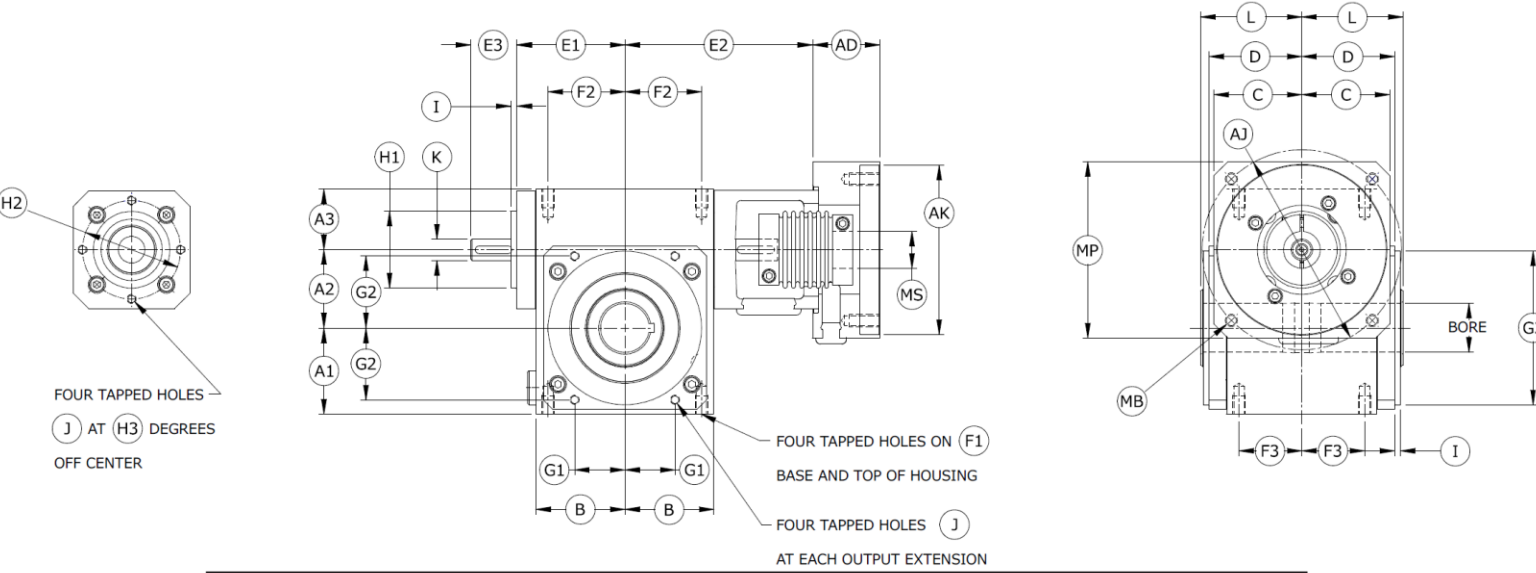

Size	A1		A2 (CD)		A3		B		C		D		E1	
	inch	mm	inch	mm	inch	mm	inch	mm	inch	mm	inch	mm	inch	mm
38	1.772	45	1.500	38.1	1.378	35.0	1.988	50.5	1.535	39.0	2.004	50.9	2.484	63.1
51	2.205	56	2.000	50.8	1.555	39.5	2.283	58.0	1.929	49.0	2.378	60.4	2.732	69.4
64	2.874	73	2.500	63.5	1.752	44.5	3.110	79.0	2.126	54.0	2.752	69.9	3.697	93.9
76	3.228	82	3.000	76.2	2.197	55.8	3.524	89.5	2.894	73.5	3.697	93.9	4.327	109.9
89	3.937	100	3.500	88.9	2.484	63.1	4.134	105	3.543	90.0	4.382	111.3	4.937	125.4

Size	E2		E3		F1	F2		F3		G1		G2		G3	
	inch	mm	inch	mm	tap	inch	mm	inch	mm	inch	mm	inch	mm	inch	mm
38	4.520	114.80	1.189	30.2	M8	1.654	42.0	1.260	32	0.721	18.31	1.356	34.43	2.520	64 h8
51	4.815	122.30	1.224	31.1	M8	1.969	50.0	1.614	41	1.287	32.69	1.838	46.69	3.937	100 h8
64	5.986	152.00	1.461	37.1	M8	2.697	68.5	1.732	44	1.581	40.15	2.257	57.34	4.724	120 h8
76	6.478	164.55	1.323	33.6	M10	3.110	79.0	2.480	63	1.785	45.34	2.548	64.73	5.276	134 h8
89	7.795	198.00	2.031	51.6	M10	3.740	95.0	3.150	80	1.831	46.50	3.171	80.54	5.709	145 h8

Size	H1		H2		H3	I		J	K			L	
	inch	mm	inch	mm	dgrs.	inch	mm	tap	inch	mm	keyway	inch	mm
38	1.811	46 h8	2.205	56	0	0.157	4	M6	0.551	14 k6	5 x 2.3 x 25	2.205	56
51	1.969	50 h8	2.520	64	0	0.157	4	M6	0.551	14 k6	5 x 2.3 x 24	2.598	66
64	2.362	60 h8	3.071	78	25	0.157	4	M8	0.748	19 k6	6 x 2.8 x 25	2.913	74
76	2.756	70 h8	3.622	92	25	0.157	4	M10	0.945	24 k6	8 x 3 x 28	3.937	100
89	3.543	90 h8	4.331	110	25	0.157	4	M10	1.102	28 k6	8 x 4 x 40	4.606	117

Size	Inch Bore			Metric Bore			Alternative Metric Bore			AD Max.	
	inch	tol.	mm	inch	tol.	mm	inch	tol.	mm	tap	mm
38	0.8754	+/- .0004	3/16 x 3/32	25	H7	8 x 3.3	22	H9	6 x 2.8	2.055	52.2
51	1.2505	+/- .0005	1/4 x 1/8	30	H7	8 x 3.3	-	-	-	2.055	52.2
64	1.6880	+/- .0005	3/8 x 3/16	35	H7	10 x 3.3	38	H9	10 x 3.3	2.717	69.0
76	1.9380	+/- .0005	1/2 x 1/4	45	H7	14 x 3.8	48	H9	14 x 3.8	2.717	69.0
89	2.4380	+/- .0005	5/8 x 5/16	60	H7	18 x 4.4	-	-	-	2.717	69.0



DIMENSION SOLID Ghost Drive "GhD" Series

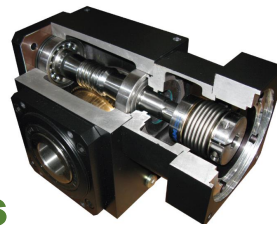

**Servo Worm Gearboxes
Ultra Quiet & Ultra Light**

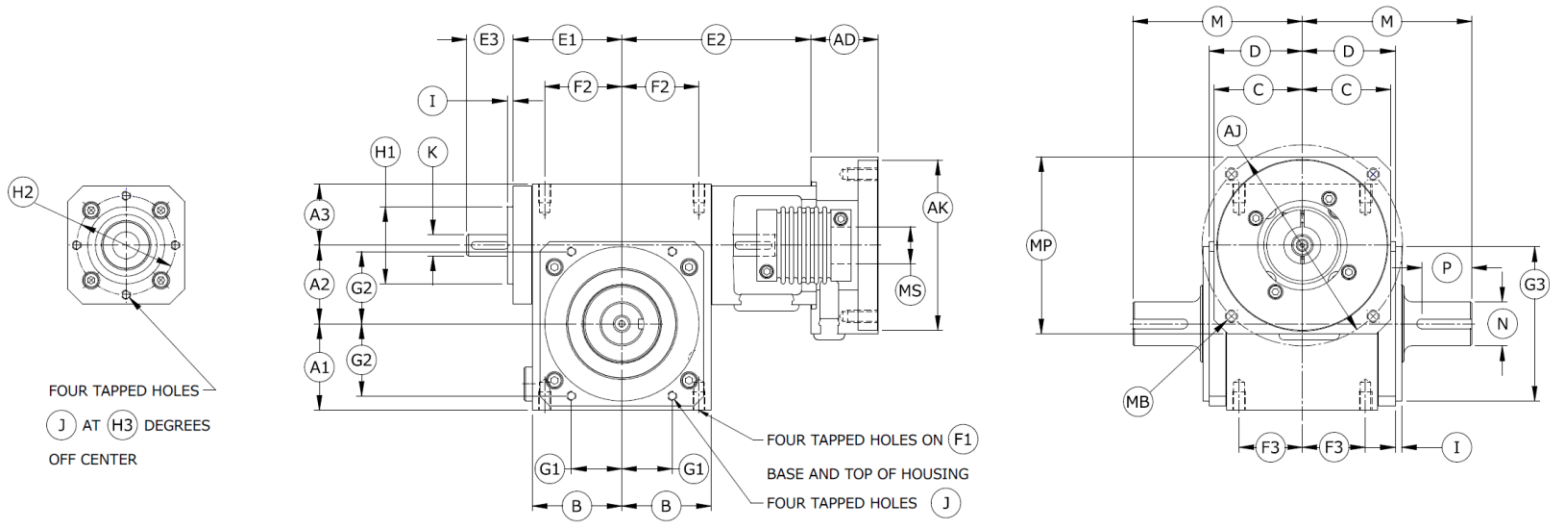

Size	A1		A2 (CD)		A3		B		C		D		E1	
	inch	mm	inch	mm	inch	mm	inch	mm	inch	mm	inch	mm	inch	mm
38	1.772	45	1.500	38.1	1.378	35.0	1.988	50.5	1.535	39.0	2.004	50.9	2.484	63.1
51	2.205	56	2.000	50.8	1.555	39.5	2.283	58.0	1.929	49.0	2.378	60.4	2.732	69.4
64	2.874	73	2.500	63.5	1.752	44.5	3.110	79.0	2.126	54.0	2.752	69.9	3.697	93.9
76	3.228	82	3.000	76.2	2.197	55.8	3.524	89.5	2.894	73.5	3.697	93.9	4.327	109.9
89	3.937	100	3.500	88.9	2.484	63.1	4.134	105	3.543	90.0	4.382	111.3	4.937	125.4

Size	E2		E3		F1	F2		F3		G1		G2		G3	
	inch	mm	inch	mm	tap	inch	mm	inch	mm	inch	mm	inch	mm	inch	mm
38	4.520	114.80	1.189	30.2	M8	1.654	42.0	1.260	32	0.721	18.31	1.356	34.43	2.520	64 h8
51	4.815	122.30	1.224	31.1	M8	1.969	50.0	1.614	41	1.287	32.69	1.838	46.69	3.937	100 h8
64	5.986	152.00	1.461	37.1	M8	2.697	68.5	1.732	44	1.581	40.15	2.257	57.34	4.724	120 h8
76	6.478	164.55	1.323	33.6	M10	3.110	79.0	2.480	63	1.785	45.34	2.548	64.73	5.276	134 h8
89	7.795	198.00	2.031	51.6	M10	3.740	95.0	3.150	80	1.831	46.50	3.171	80.54	5.709	145 h8

Size	H1		H2		H3	I		J	K			M	
	inch	mm	inch	mm	dgrs.	inch	mm	tap	inch	mm	keyway	inch	mm
38	1.811	46 h8	2.205	56	0	0.157	4	M6	0.551	14 k6	5 x 2.3 x 25	3.386	86
51	1.969	50 h8	2.520	64	0	0.157	4	M6	0.551	14 k6	5 x 2.3 x 24	4.331	110
64	2.362	60 h8	3.071	78	25	0.157	4	M8	0.748	19 k6	6 x 2.8 x 25	4.882	124
76	2.756	70 h8	3.622	92	25	0.157	4	M10	0.945	24 k6	8 x 3 x 28	6.417	164
89	3.543	90 h8	4.331	110	25	0.157	4	M10	1.102	28 k6	8 x 4 x 40	7.874	200

Size	N (Inch)		P (Inch)		N (mm)			P (mm)*			AD Max.	
	inch	tol.	keyway	length	mm	tol.	keyway	inch	length	ofst.	Inch	mm
38	0.7497	+/- .0003	3/16 x 3/32	26	20	k6	6 x 3.5	22	22	4	2.055	52.2
51	1.1247	+/- .0003	1/4 x 1/8	38	25	k6	8 x 4	36	36	4	2.055	52.2
64	1.2497	+/- .0003	1/4 x 1/8	40	30	k6	8 x 4	40	40	4	2.717	69.0
76	1.4997	+/- .0003	3/8 x 3/16	45	35	k6	10 x 5	50	50	5	2.717	69.0
89	1.8747	+/- .0003	1/2 x 1/4	60	45	k6	14 x 5.5	63	63	5	2.717	69.0



DIMENSION END MOUNT Ghost Drive “GhD” Series

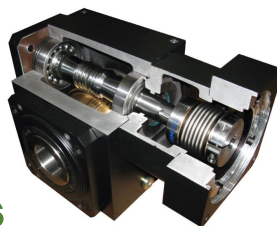

**Servo Worm Gearboxes
Ultra Quiet & Ultra Light**

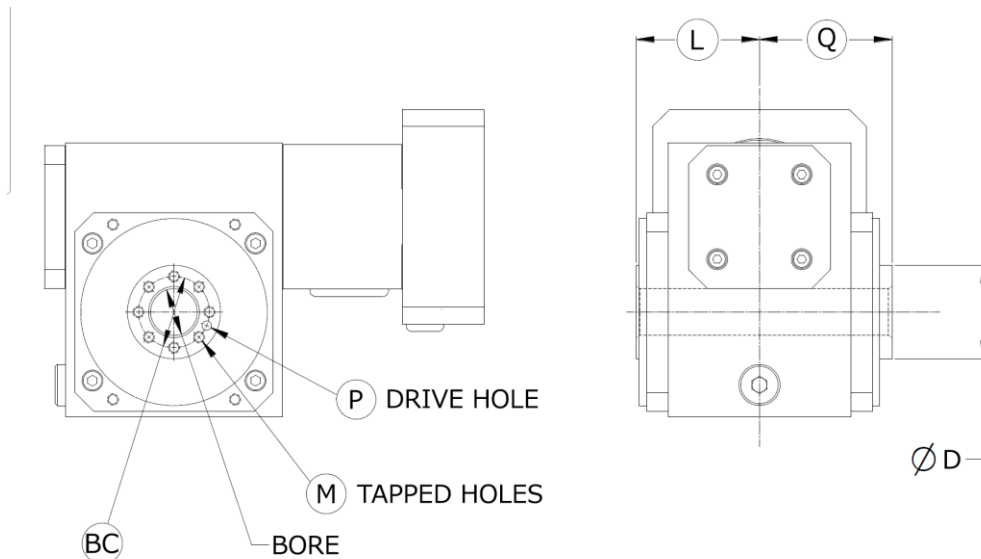

Optional Shaft End Mount

Size	BC	L	M	P	Q	BORE	Ø D
38	28	56	4 x M6 x 1, 12 Deep	5 H9, 10 Deep	61	16 H8	40 h11
51	38	66	8 x M6 x 1, 12 Deep	5 H9, 10 Deep	71	25 H7	50 h11
64	50	74	8 x M8 x 1.25, 16 Deep	6 H9, 10 Deep	79	30 H7	65 h11
76	60	100	8 x M8 x 1.25, 16 Deep	8 H9, 10 Deep	105	35 H7	80 h11
89	70	117	8 x M10 x 1.5, 20 Deep	8 H9, 10 Deep	122	45 H7	90 h11



Servo Worm Gearboxes Ultra Quiet Cast Iron Housing

Double Enveloping Worm Cast Iron Housing

Cost Saving Features

Ask about Self-Locking Ratios

Maintenance Free

Factory filled with synthetic gear oil
No lubrication service throughout unit life
Anodized housing, double oil seals and O-rings provide IP65 protection, ensure worry-free operation and protection against harsh environments

Double Enveloping Worm Gearing

High torque capacity
High efficiency
Quiet and smooth running
Exact ratios 5:1 and 60:1 in a single stage
High torsional rigidity

Two Levels of Precision

Low Backlash
Standard Backlash - long lasting ruggedness for less demanding applications

Hollow Shaft Standard

Compact mounting saves space
No coupling required saves cost
Single and double oil extended solid shafts provide mounting flexibility

Easy Motor Mounting

Integrated zero backlash bellows coupling provides fast, error-free alignment
Integrated motor flange mounts directly to your servomotor, NEMA motor, or IEC motor



Sizes

FeD15SW
FeD20SW
FeD25SW
FeD30SW
FeD35SW

- **CUSTOM RATIOS**
- **CUSTOM BORES**
- **CUSTOM ADAPTERS**
- **CUSTOM MOUNTING**
- **CUSTOM SEALS, etc.**

Fangtooth will tackle any solution by making a custom to fit your exact requirement



CALL TODAY





ORDERING CODES

IronDRIVE “FeD” Series

Servo Worm Gearboxes
Ultra Quiet Cast Iron Housing

Model: FeD015SW-S010Q-25MHHK/MS2N04

Gearbox Series
FeD – IronDrive

Gearbox Size
015 – 1.500 inch CD
020 – 2.000 inch CD
025 – 2.500 inch CD
030 – 3.000 inch CD
035 – 3.500 inch CD

Gearbox Drive Type
SW – Servo Worm

Gearbox Backlash
S – Standard
L – Low

Gearbox Ratio

005 – 5:1	020 – 20:1
006 – 6:1	025 – 25:1
007 – 7:1	030 – 30:1
008 – 8:1	040 – 40:1
009 – 9:1	050 – 50:1
010 – 10:1	060 – 60:1
015 – 15:1	

Gearbox Input
SIP – Single Input
DIP – Dual Input
Motor Model – Mounting Kit

Gearbox Output Type
K – Keyed
S – Smooth
E – End Mount (Flange)

Gearbox Output Location
HH – Hollow Bore Through
H1 – Hollow Bore “1” side
H2 – Hollow Bore “2” side
ZZ – Solid Shaft, Double Ext
Z1 – Solid Shaft “1” side
Z2 – Solid Shaft “2” side

Gearbox Output Size
– size in 16th of an inch
##M – size in mm

Gearbox Mounting
Q – Standard



RATINGS

IronDRIVE “FeD” Series



Servo Worm Gearboxes
Ultra Quiet Cast Iron Housing

Size			Ratio													
			5:1	6:1	7:1	8:1	9:1	10:1	15:1	20:1	25:1	30:1	40:1	50:1	60:1	
15	Output torque (lb.in.)	E-Stop	1620						1920	1911	1848		1701	1314	1326	1134
		Accel/decel	411						523	538	525		504	459	455	423
		Run	314						412	427	422		405	369	366	340
	Input torque	Accel/decel	89						58	41	31		21	15	13	10
		Run	71						48	34	26		18	13	11	9
20	Output torque (lb.in.)	E-Stop	3400	3600	3800	3900	3900	3900	4000	3700	3700	3500	3200	2700	2600	
		Accel/decel	800	880	930	980	1000	1020	1060	1030	1030	990	940	900	870	
		Run	590	650	690	730	740	760	790	790	780	750	720	690	660	
	Input torque	Accel/decel	174	159	146	135	124	113	80	61	50	42	32	25	21	
		Run	130	119	108	101	91	85	61	46	38	32	24	19	16	
25	Output torque (lb.in.)	E-Stop	6600	7100	7300	7600	7700	7800	7800	7500	7000	6900	6000	5500	5400	
		Accel/decel	1474	1632	1718	1816	1850	1895	1964	1920	1918	1839	1752	1688	1620	
		Run	1063	1179	1242	1312	1335	1373	1427	1411	1404	1347	1285	1238	1189	
	Input torque	Accel/decel	320	296	270	249	228	211	149	114	91	77	59	47	39	
		Run	123	214	195	180	165	153	108	83	67	56	42	34	28	
30	Output torque (lb.in.)	E-Stop	11600	12600	13100	13700	13700	13800	13900	13300	12700	12300	11100	9700	9600	
		Accel/decel	2434	2710	2871	3050	3138	3244	3372	3301	3300	3162	3015	2905	2789	
		Run	1738	1940	2060	2196	2258	2337	2433	2411	2404	2303	2197	2116	2032	
	Input torque	Accel/decel	529	491	451	419	387	360	255	196	157	132	102	81	66	
		Run	378	351	323	302	279	260	184	142	114	96	72	58	48	
35	Output torque (lb.in.)	E-Stop	21447	23397	24174	25179	25350	25569	25533	24948	23820	22749	20292	18372	18030	
		Accel/decel	4247	4750	5027	5343	5477	5648	5870	5744	5741	5502	5247	5055	4853	
		Run	3014	3376	3577	3809	3908	4032	4202	4166	4143	3980	3796	3657	3511	
	Input torque	Accel/decel	923	861	789	734	676	628	445	342	277	232	175	140	117	
		Run	662	618	562	529	482	453	322	248	207	168	127	102	85	

Torque ratings based on 2000 RPM, service factor 1.0.

RATINGS

IronDRIVE “FeD” Series



Servo Worm Gearboxes Ultra Quiet Cast Iron Housing

Inertia of the complete speed reducer, at the input shaft

Size	Ratio to 1	5	6	7	8	9	10	15	20	25	30	40	50	60
15	Total Inertia - kg cm ²	1.5					1.3	1.3	1.3		1.3	1.3	1.3	1.3
	Total Inertia - lb·in·s ² ×10 ⁻⁴	13.2					11.7	11.5	11.4		11.3	11.3	11.3	11.3
20	Total Inertia - kg cm ²	2.6	2.3	2.2	2.1	2.0	2.0	1.9	1.9	1.8	1.8	1.8	1.8	1.8
	Total Inertia - lb·in·s ² ×10 ⁻⁴	22.8	20.7	19.5	18.6	18.1	17.7	16.7	16.4	16.2	16.2	16.1	16.0	16.0
25	Total Inertia - kg cm ²	6.0	5.2	4.8	4.5	4.3	4.1	3.8	3.6	3.6	3.6	3.5	3.5	3.5
	Total Inertia - lb·in·s ² ×10 ⁻⁴	53.0	46.2	42.1	39.5	37.7	36.4	33.3	32.2	31.7	31.4	31.2	31.0	31.0
30	Total Inertia - kg cm ²	13.0	10.8	9.5	8.6	8.0	7.6	6.6	6.3	6.1	6.0	5.9	5.9	5.9
	Total Inertia - lb·in·s ² ×10 ⁻⁴	115.1	95.6	83.9	76.3	71.0	67.3	58.4	55.3	53.9	53.1	52.4	52.0	51.8
35	Total Inertia - kg cm ²	27.6	23.2	20.5	18.8	17.6	16.7	14.7	14.0	13.7	13.5	13.3	13.2	13.2
	Total Inertia - lb·in·s ² ×10 ⁻⁴	244.4	205.1	181.4	166.0	155.5	147.9	130.1	123.8	120.9	119.4	117.8	117.1	116.7

Torsional Stiffness of Model RG Units at output, input held (less coupling)

	Unit Size									
	15		20		25		30		35	
	Lb.In./min.	Nm /min.	Lb.In./min.	Nm /min.	Lb.In./min.	Nm /min.	Lb.In./min.	Nm /min.	Lb.In./min.	Nm /min.
Stiffness	91	10.3	157	17.8	204	23.1	367	41.6	699	79.2

	Unit Sizes				
	15	20	25	30	35
Standard Backlash (arc. mins.)	27	17	14	11	11
Low Backlash (arc. mins.)	11	8	7	5	4

DIMENSIONS HOLLOW IronDRIVE “FeD” Series



Servo Worm Gearboxes Ultra Quiet Cast Iron Housing

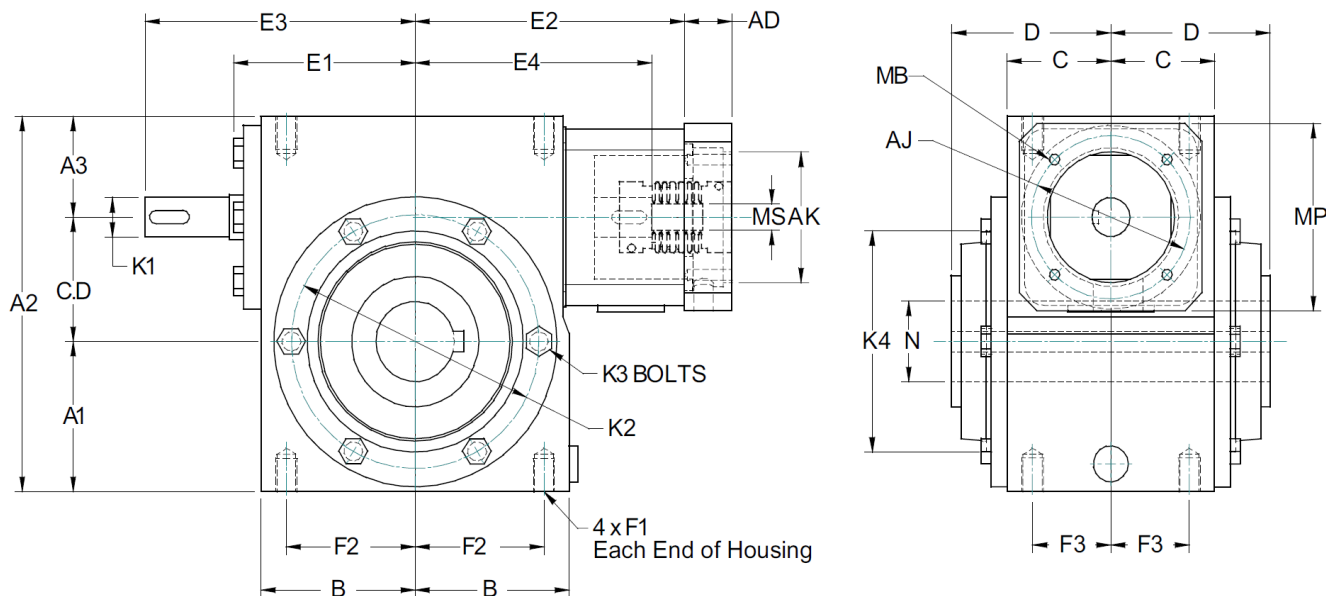

Size	CD		A1		A2		A3		B		C		D	
	inch	mm	inch	mm	inch	mm	inch	mm	inch	mm	inch	mm	inch	mm
15	1.500	38.1	1.625	41.3	4.75	121	1.625	41.3	1.78	45	1.66	42	2.31	59
20	2.000	50.8	2.500	63.5	6.25	159	1.750	44.5	2.41	61	1.57	40	2.63	67
25	2.500	63.5	3.000	76.2	7.50	191	2.000	50.8	3.09	79	1.94	49	2.91	74
30	3.000	76.2	3.625	92.1	9.06	230	2.438	61.9	3.86	98	2.56	65	3.94	100
35	3.500	88.9	4.250	108	10.31	262	2.563	65.1	4.44	113	3.44	87	4.61	117

Size	E1		E2		E3		E4		F1	F2		F3		K1			K2	
	inch	mm	inch	mm	inch	mm	inch	mm	tap	inch	mm	inch	mm	inch	mm	keyway (mm)	inch	mm
15	2.17	55	4.46	113	3.31	84	3.62	91.9	M8	1.44	36.5	1.31	33.4	0.551	14 k6	5 x 2.3 x 16	3.125	79.4
20	2.88	73	5.13	130	4.59	117	4.30	109.2	M10	2.00	50.8	1.13	28.6	0.551	14 k6	5 x 2.3 x 25	4.125	104.8
25	3.65	93	6.25	159	5.25	133	5.44	138.2	M10	2.56	65.1	1.50	38.1	0.748	19 k6	6 x 2.8 x 25	4.938	125.4
30	4.53	115	6.66	169	6.69	170	5.85	148.6	M12	3.19	81	1.94	49.2	0.945	24 k6	8 x 3 x 25	6.125	155.6
35	5.16	131	7.44	189	7.75	197	6.63	168.4	M12	3.81	96.9	2.81	71.5	1.103	28 k6	8 x 4 x 32	7.250	184.2

Size	K3 bolts	K4 pilot dia.		N (inch)			N (mm)			AD Max		AK	AJ	MP	MB	MS	Weight lbs
	mm	inch	mm	inch	tol	keyway	mm	tol	keyway	inch	mm						
15	M6	2.498	63.4	0.876	+/- .001	3/16 x 3/32	25	H7	8 x 3.3	2.055	52.2	Will Provide CAD for your motor					15
20	M8	3.336	84.7	1.251	+/- .001	1/4 x 1/8	30	H7	8 x 3.3	2.055	52.2						27
25	M8	4.217	107.1	1.688	+/- .001	3/8 x 3/16	35	H7	10 x 3.3	2.717	69.0						44
30	M10	5.342	135.7	1.938	+/- .001	1/2 x 1/4	45	H7	14 x 3.8	2.717	69.0						78
35	M10	6.467	164.3	2.438	+/- .001	5/8 x 5/16	60	H7	18 x 4.4	2.717	69.0						116



DIMENSIONS SOLID IronDRIVE "FeD" Series



Servo Worm Gearboxes Ultra Quiet Cast Iron Housing

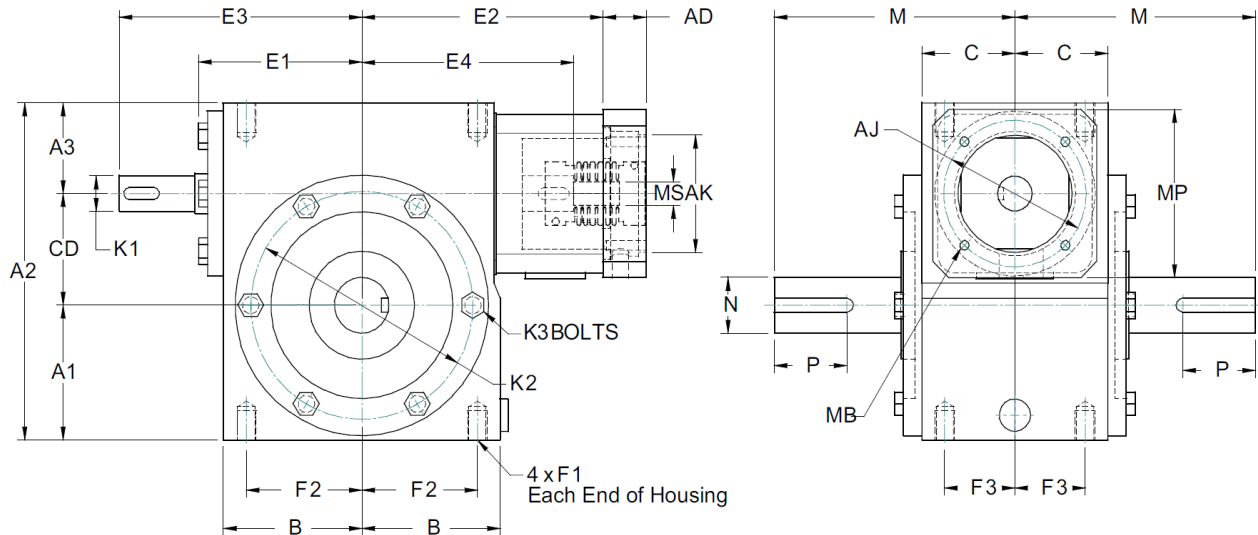

Size	CD		A1		A2		A3		B		C		M	
	inch	mm	inch	mm	inch	mm	inch	mm	inch	mm	inch	mm	inch	mm
15	1.500	38.1	1.625	41.3	4.75	121	1.625	41.3	1.78	45	1.66	42	3.50	89
20	2.000	50.8	2.500	63.5	6.25	159	1.750	44.5	2.41	61	1.57	40	4.63	118
25	2.500	63.5	3.000	76.2	7.50	191	2.000	50.8	3.09	79	1.94	49	4.78	121
30	3.000	76.2	3.625	92.1	9.06	230	2.438	61.9	3.86	98	2.56	65	6.64	169
35	3.500	88.9	4.250	108	10.31	262	2.563	65.1	4.44	113	3.44	87	8.25	210

Size	E1		E2		E3		E4		F1	F2		F3		K1			K2		K3 bolts
	inch	mm	inch	mm	inch	mm	inch	mm	tap	inch	mm	inch	mm	inch	mm	keyway(mm)	inch	mm	mm
15	2.17	55	4.46	113	3.31	84	3.62	91.9	M8	1.44	36.5	1.31	33.4	0.551	14 k6	5 x 2.3 x 16	3.125	79.4	M6
20	2.88	73	5.13	130	4.59	117	4.30	109.2	M10	2.00	50.8	1.13	28.6	0.551	14 k6	5 x 2.3 x 25	4.125	104.8	M8
25	3.65	93	6.25	159	5.25	133	5.44	138.2	M10	2.56	65.1	1.50	38.1	0.748	19 k6	6 x 2.8 x 25	4.938	125.4	M8
30	4.53	115	6.66	169	6.69	170	5.85	148.6	M12	3.19	81	1.94	49.2	0.945	24 k6	8 x 3 x 25	6.125	155.6	M10
35	5.16	131	7.44	189	7.75	197	6.63	168.4	M12	3.81	96.9	2.81	71.5	1.103	28 k6	8 x 4 x 32	7.250	184.2	M10

Size	N (inch)		P (inch)		N (inch)		P (mm)*			AD Max		AK	AJ	MP	MB	MS	Weight lbs.
	inch	tol	Keyway	length	mm	tol	keyway	length	offset	inch	mm						
15	0.7497	± 0.0003	3/16 x 3/32	0.89	20	k6	6 x 3.5	22	4	2.055	52.2	Will Provide CAD for your motor					16
20	1.1245	± 0.0005	1/4 x 1/8	1.50	25	k6	8 x 4	36	4	2.055	52.2						28
25	1.2495	± 0.0005	1/4 x 1/8	1.38	30	k6	8 x 4	40	3	2.717	69.0						45
30	1.4995	± 0.0005	3/8 x 3/16	2.00	38	k6	10 x 5	50	3	2.717	69.0						73
35	1.8745	± 0.0005	1/2 x 1/4	2.62	45	k6	14 x 5.5	63	5	2.717	69.0						112

*Note: P (mm) is length of pocket-style keyway and offset from shaft end.



DIMENSIONS FLANGE IronDRIVE “FeD” Series



Servo Worm Gearboxes
Ultra Quiet Cast Iron Housing

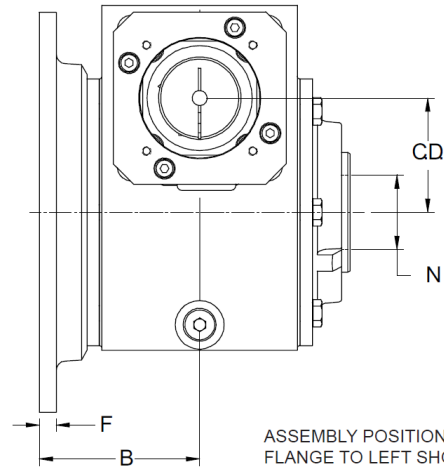
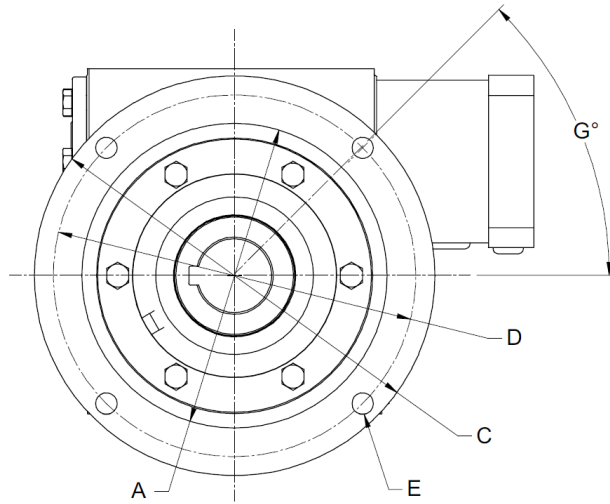

ASSEMBLY POSITION “F3”
FLANGE TO LEFT SHOWN HERE

BOLT PATTERN ARRANGEMENT SHOWN APPLIES TO SIZES 15 / 30 / 35

Size	CD		A		B		C		D		E		F		G	N (if hollow shaft)	
	inch	mm	inch	mm	inch	mm	inch	mm	inch	mm	inch	mm	inch	mm	degree	mm	tol
15	1.50	38	4.500	114.3	3.40	86	6.63	168	5.88	149	0.41	10	0.38	10	45	25	H7
20	2.00	51	5.376	136.6	3.41	87	8.00	203	7.00	178	0.41	10	0.50	13	90	30	H7
25	2.50	64	6.626	168.3	3.52	89	9.25	235	8.25	210	0.47	12	0.50	13	90	35	H7
30	3.00	76	7.751	196.9	4.35	111	10.50	267	9.50	241	0.56	14	0.50	13	45	45	H7
35	3.50	89	8.751	222.3	5.08	129	11.75	298	10.50	267	0.56	14	0.50	13	45	60	H7



Servo & NEMA Worm Gearboxes

Ultra Quiet Cast Iron Housing

Double Enveloping Worm Cast Iron Housing

Heavy Drive "HvD" Series



Ask about Self-Locking Ratios

Many Housing Configurations

Double Enveloping Worm Gearing
High torque capacity
High efficiency
Quiet and smooth running
Exact ratios 5:1 and 60:1 in a single stage
High torsional rigidity

Hollow Shaft Standard
Compact mounting saves space
No coupling required saves cost
Single and double oil extended solid shafts provide mounting flexibility

Easy Motor Mounting
Integrated zero backlash bellows coupling provides fast, error-free alignment
Integrated motor flange mounts directly to your servomotor, NEMA motor, or IEC motor

- **CUSTOM RATIOS**
- **CUSTOM BORES**
- **CUSTOM ADAPTERS**
- **CUSTOM MOUNTING**
- **CUSTOM SEALS, etc.**

Fangtooth will tackle any solution by making a custom to fit your exact requirement



Servo Sizes

- HvD035SW**
- HvD040SW**
- HvD050SW**
- HvD060SW**
- HvD070SW**
- HvD080SW**
- HvD100SW**
- HvD120SW**

NEMA Sizes

- HvD015NW**
- HvD020NW**
- HvD025NW**
- HvD030NW**
- HvD035NW**
- HvD040NW**
- HvD050NW**
- HvD060NW**
- HvD070NW**
- HvD080NW**
- HvD100NW**
- HvD120NW**

CALL TODAY



Fangtooth Heavy Drive HvD
Ultra Quiet Cast Iron
Gearbox Technical Information

www.fangtooth-linear.com



ORDERING CODES

heavyDRIVE “HvD” Series

Servo Worm Gearboxes
Ultra Quiet Cast Iron Housing

Model: HvD035SW-S010V-044HF1/MS2N04

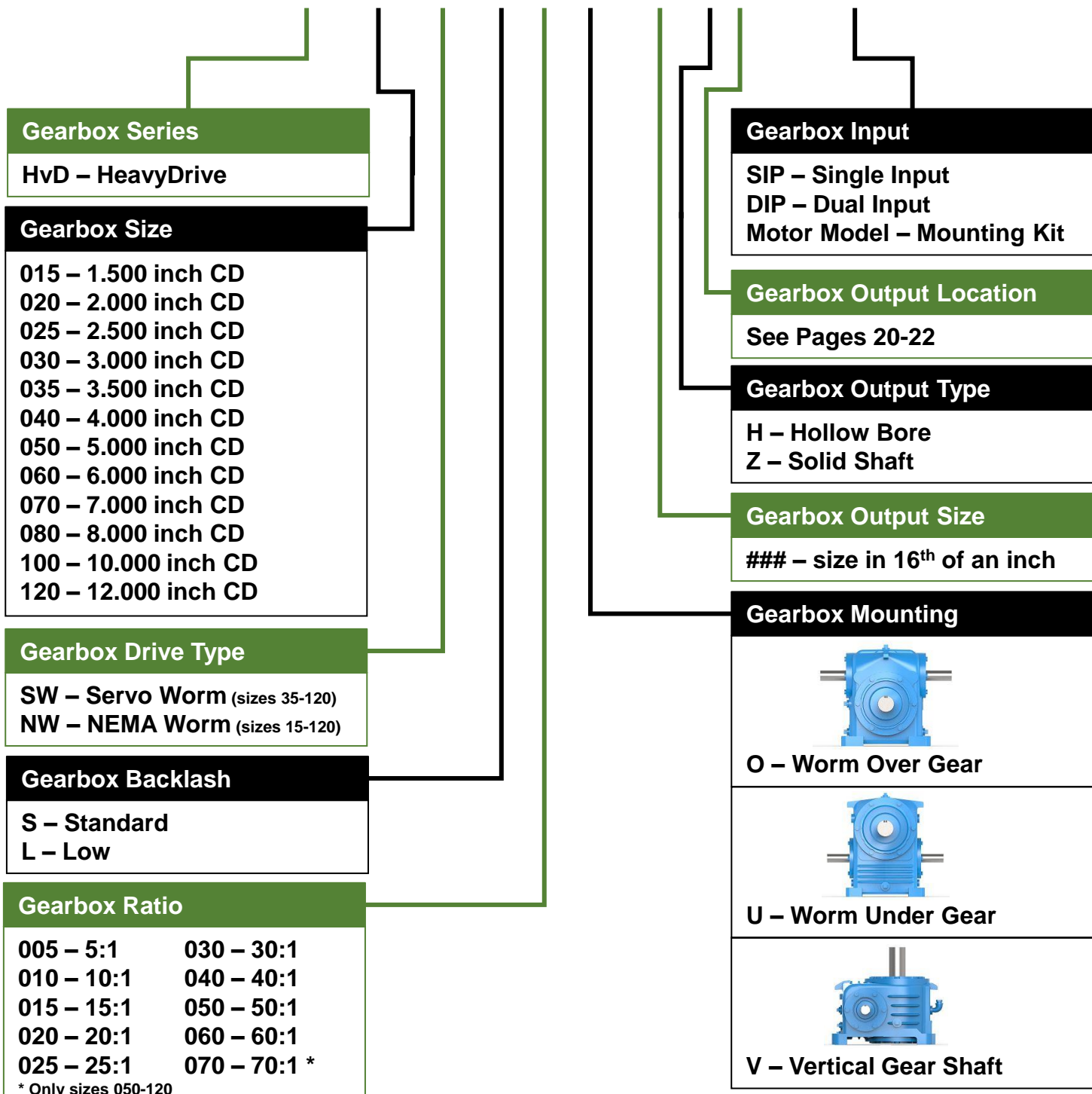



MOUNTING "U" & "O" heavyDRIVE "HvD" Series

Servo Worm Gearboxes Ultra Quiet Cast Iron Housing

Top View, Floor Mounted

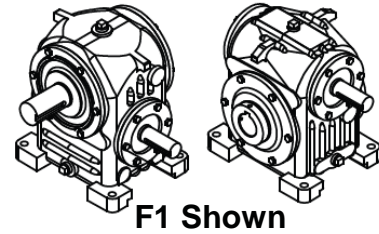
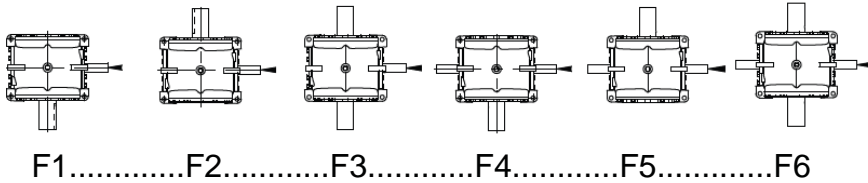

Ceiling Mounted

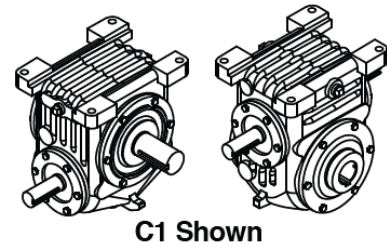
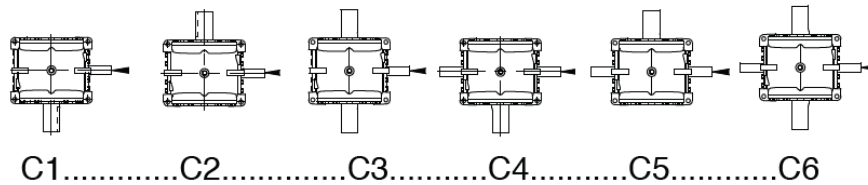

Wall Mounted, Worm Vertical Up

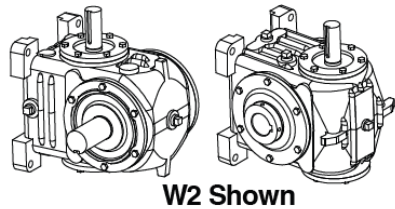
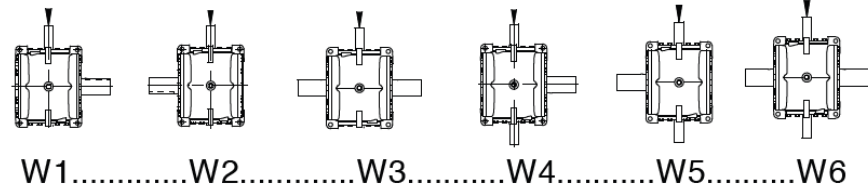

Wall Mounted, Worm Vertical Down

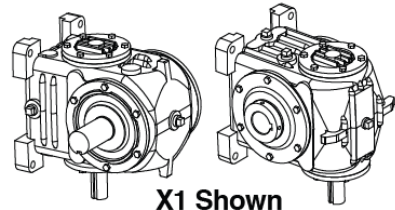
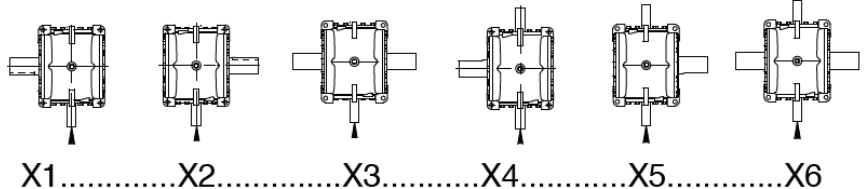

Wall Mounted, Worm Horizontal to the Left

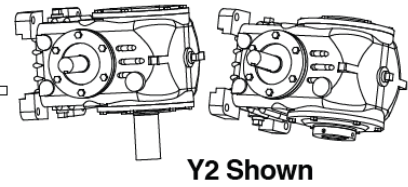
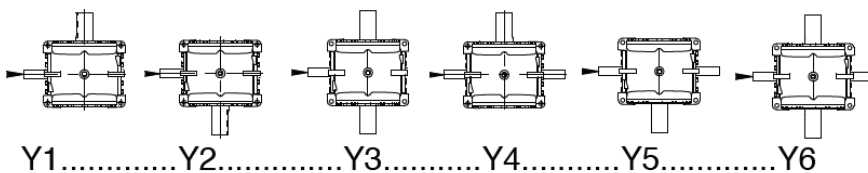

Wall Mounted, Worm Horizontal to the Right

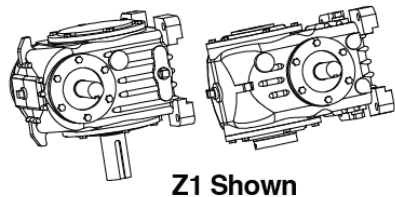
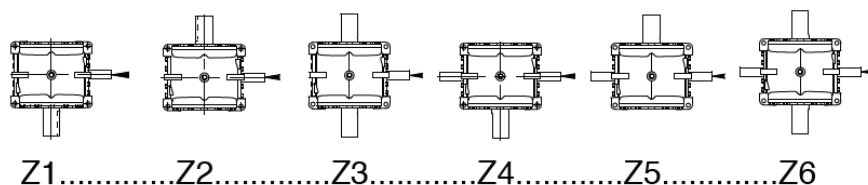



MOUNTING "V" heavyDRIVE "HvD" Series

Servo Worm Gearboxes Ultra Quiet Cast Iron Housing

Top View, Floor Mounted

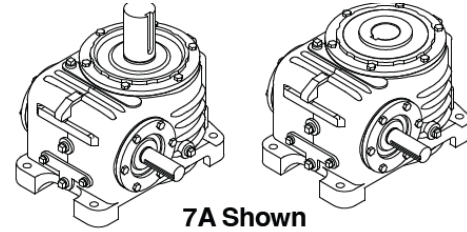
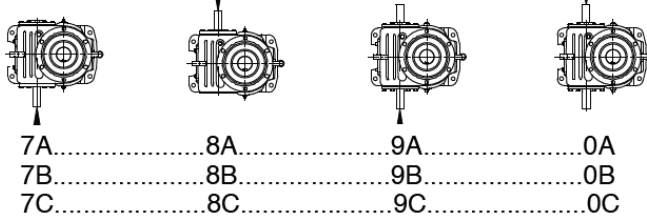

Ceiling Mounted

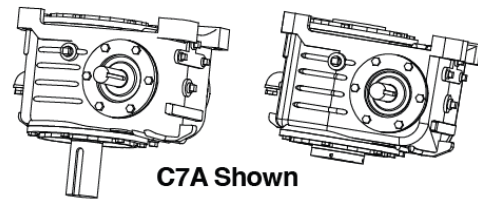
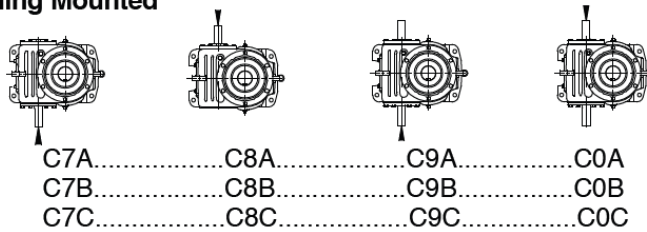

Wall Mounted, Worm Vertical Up

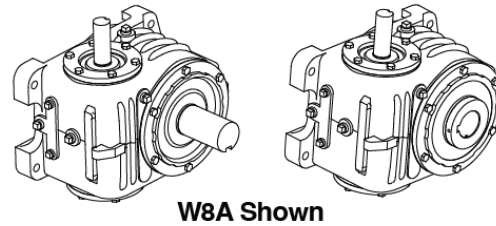
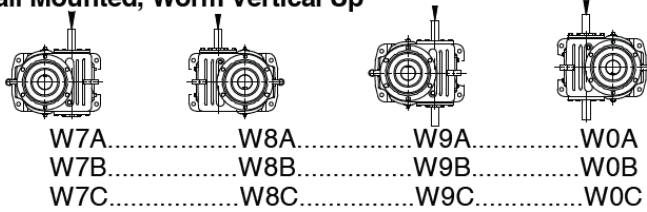

Wall Mounted, Worm Vertical Down

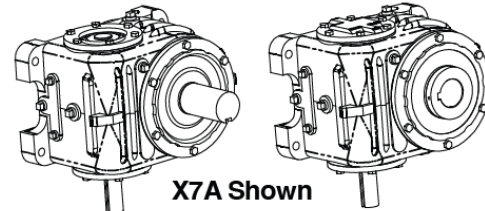
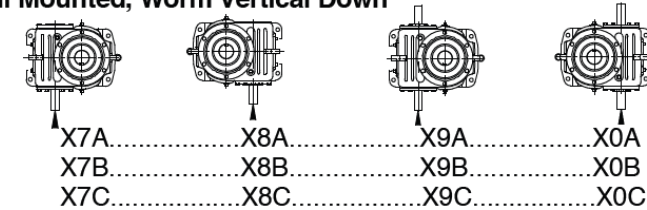

Size 100 and larger - Contact Cone Drive Regarding Lubrication of Upper Worm Bearing

Wall Mounted, Worm Horizontal Under Gear

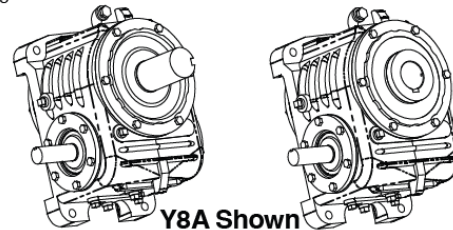
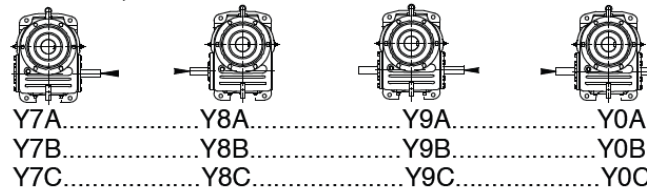

Wall Mounted, Worm Horizontal Over Gear

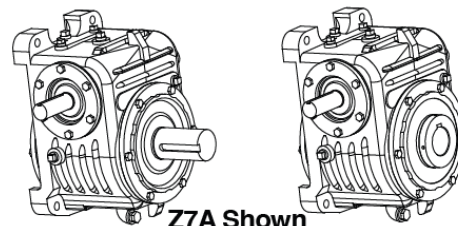
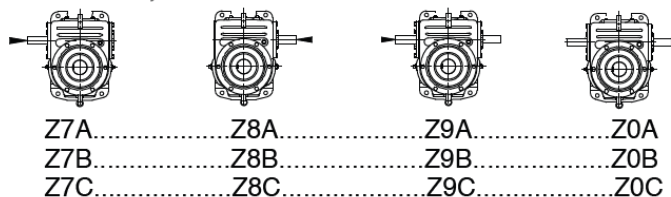



MOUNTING "UU" heavyDRIVE "HvD" Series

Servo Worm Gearboxes Ultra Quiet Cast Iron Housing

Top View, Floor Mounted

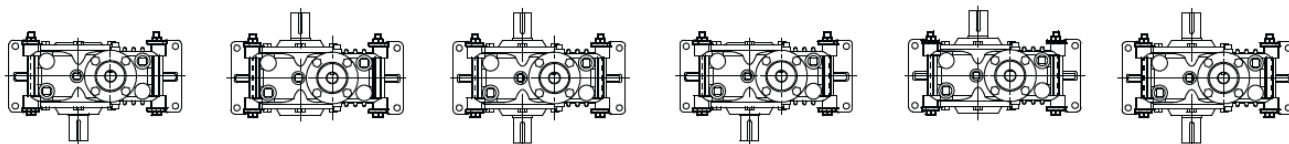

F1.....F2.....F3.....F4.....F5.....F6

Ceiling Mounted

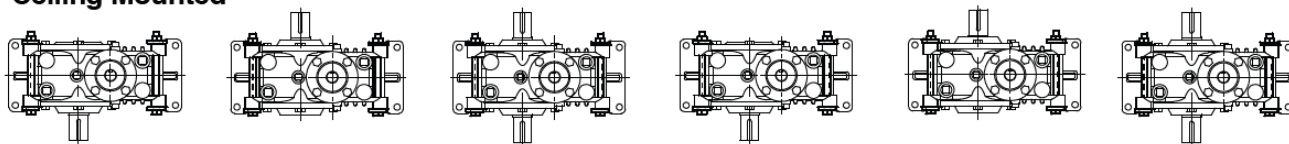

C1.....C2.....C3.....C4.....C5.....C6

Wall Mounted, Worm Under Gear

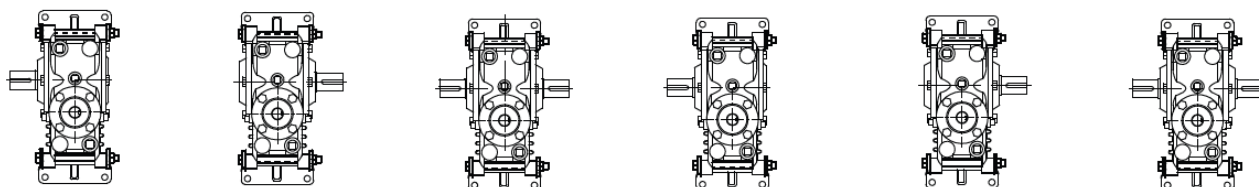

W1.....W2.....W3.....W4.....W5.....W6

Wall Mounted, Worm Over Gear

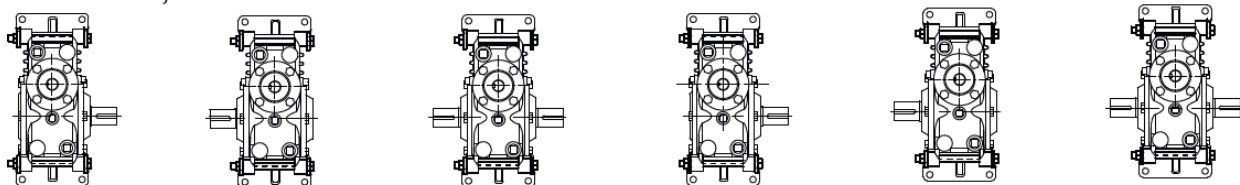

X1.....X2.....X3.....X4.....X5.....X6

Wall Mounted, Worm to the Left of Gear

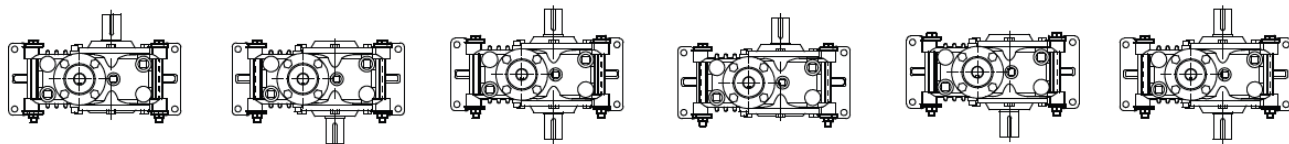

Y1.....Y2.....Y3.....Y4.....Y5.....Y6

Wall Mounted, Worm to Right of Gear

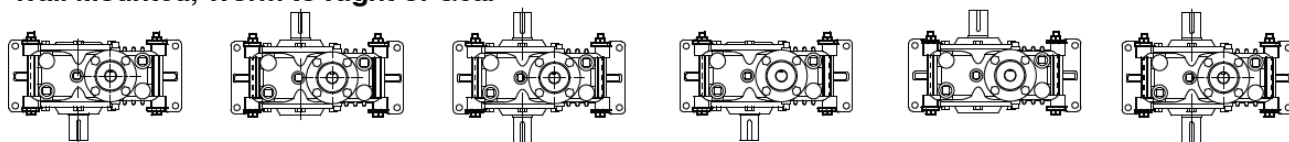

Z1.....Z2.....Z3.....Z4.....Z5.....Z6



DIMENSIONS Size 15 heavyDRIVE "HvD" Series

AGMA HORSEPOWER & OUTPUT TORQUE RATINGS FOR 1.0 SERVICE FACTOR									
		Worm RPM							
Ratio to 1		100	200	300	580	720	870	1150	1750
5	Me. HP	0.24	0.45	0.64	1.13	1.35	1.58	1.94	2.51
	Efficiency	89	90	91	91	91	92	92	92
	O.T.	670	635	610	560	540	530	490	420
10	Me. HP	0.16	0.31	0.44	0.78	0.94	1.10	1.37	1.81
	Efficiency	83	85	86	87	87	89	90	90
	O.T.	860	825	800	745	720	715	675	590
15	Me. HP	0.13	0.25	0.36	0.63	0.76	0.89	1.11	1.48
	Efficiency	79	81	82	85	85	87	88	88
	O.T.	990	955	925	880	855	845	805	705
20	Me. HP	0.10	0.19	0.27	0.49	0.58	0.68	0.85	1.14
	Efficiency	75	77	78	83	83	83	84	85
	O.T.	955	930	895	880	850	825	785	700
30	Me. HP	0.07	0.13	0.18	0.33	0.40	0.46	0.58	0.77
	Efficiency	68	70	72	75	75	79	80	80
	O.T.	880	855	835	805	780	795	760	665
40	Me. HP	0.05	0.10	0.14	0.25	0.30	0.35	0.43	0.58
	Efficiency	61	63	67	72	75	75	76	76
	O.T.	795	770	785	775	785	760	725	635
50	Me. HP	0.04	0.08	0.11	0.20	0.24	0.28	0.35	0.46
	Efficiency	54	60	64	70	70	72	73	73
	O.T.	705	735	750	755	735	730	700	610
60	Me. HP	0.03	0.06	0.09	0.16	0.20	0.23	0.29	0.39
	Efficiency	53	59	61	66	66	69	70	70
	O.T.	695	725	715	710	690	700	670	585

Model HvD015 – Worm Over Gear net wt. 11 lbs

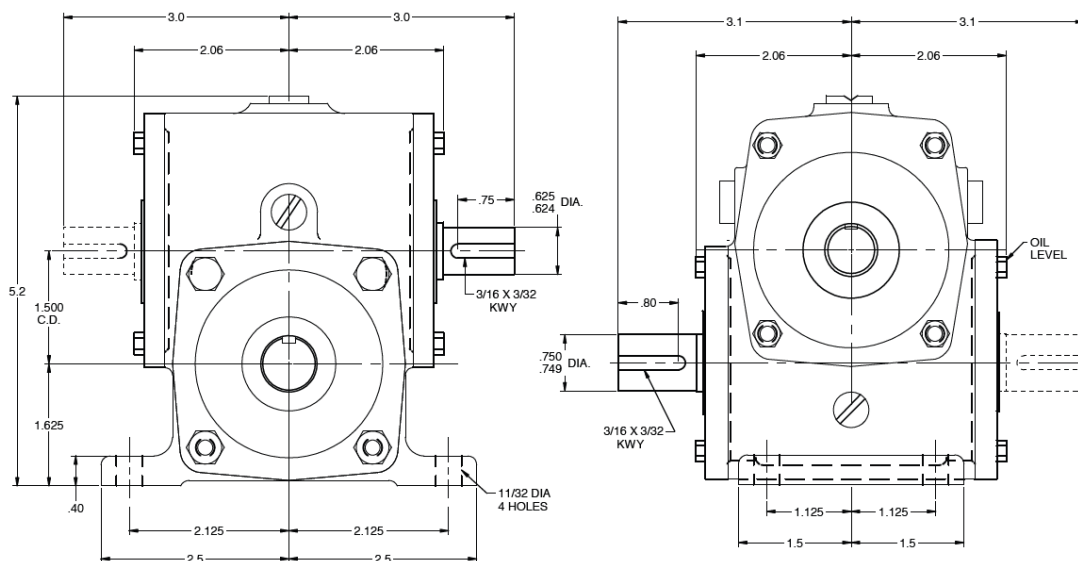

Model HvD015 – Worm Under Gear net wt. 11 lbs

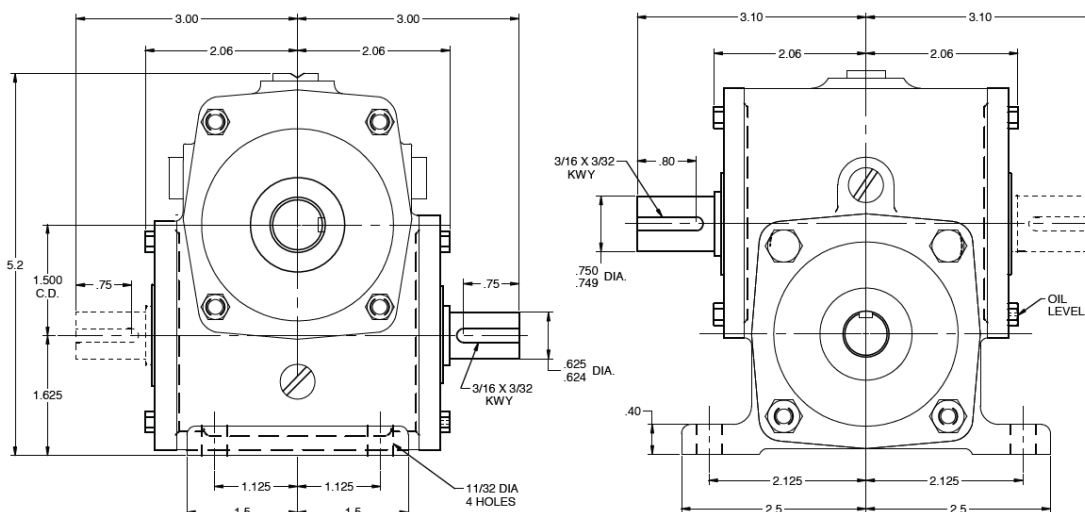



DIMENSIONS Size 20 heavyDRIVE "HvD" Series

BORE INCHES	GEARSHAFT NUMBER	KEYWAY SIZE
1.375*	20-S60-106	1/4 X 1/8
1.250*	20-S60-104	1/4 X 1/8
1.1875*	20-S60-103	1/4 X 1/8
1.125*	20-S60-102	1/4 X 1/8
1.000*	20-S60-100	1/4 X 1/8

Size 20 Solid Shaft

Model HvD020 – Worm Over Gear net wt. 26 lbs

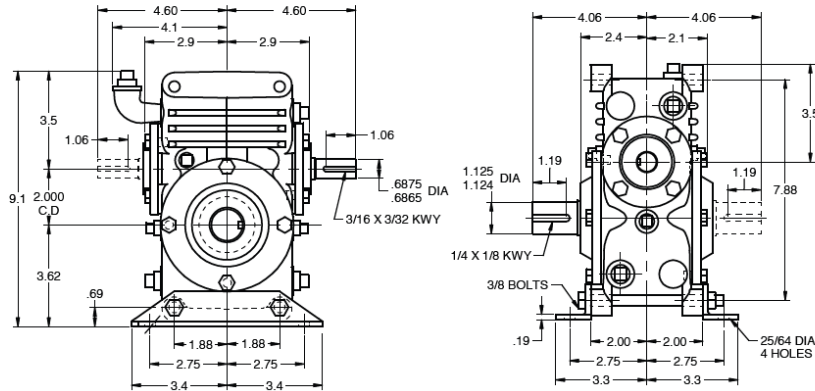

Hollow Shaft

net wt. 27 lbs

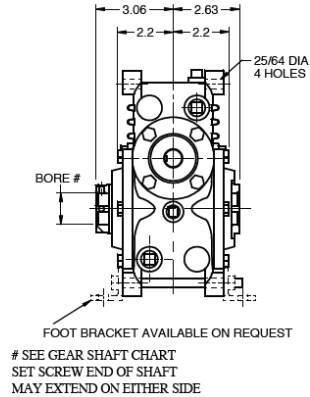

Model HvD020 – Worm Under Gear net wt. 26 lbs

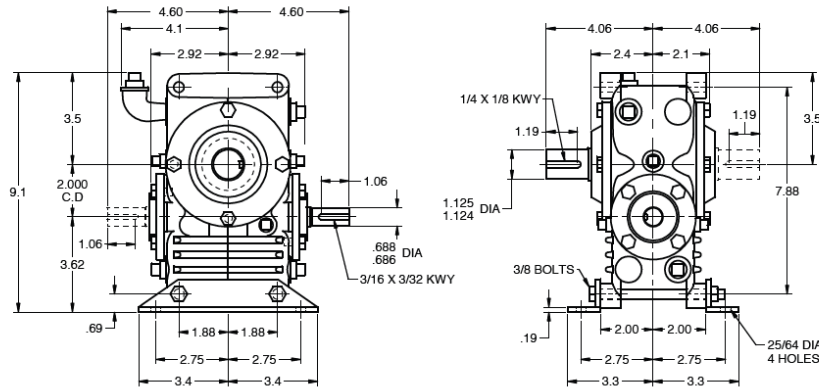

net wt. 27 lbs

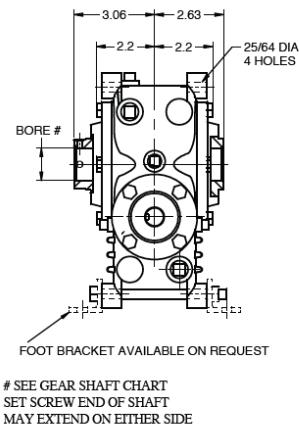

Model HvD020 – Vertical Gear Shaft

net wt. 26 lbs

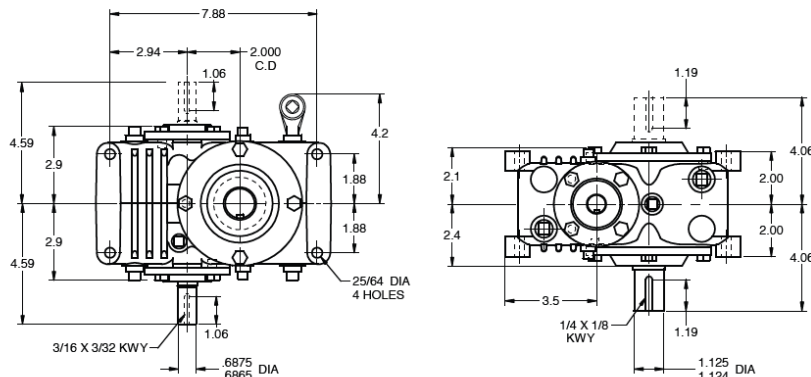

net wt. 27 lbs

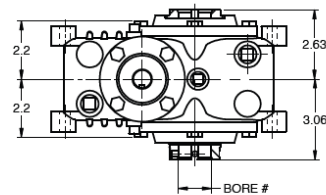

INPUT AND OUTPUT SHAFT MAY EXTEND ON EITHER SIDE OR MAY BE DOUBLE EXTENDED

SEE GEAR SHAFT CHART SET SCREW END OF SHAFT MAY EXTEND ON EITHER SIDE
WHEN REVIEWING END OF SHAFT MODEL REFER TO COMPLETE DIMENSIONS ON SAME SOLID SHAFT MODEL SHOWN AT LEFT.



RATINGS Size 20

heavyDRIVE "HvD" Series

Servo Worm Gearboxes
Ultra Quiet Cast Iron Housing



AGMA HORSEPOWER & OUTPUT TORQUE RATINGS FOR 1.0 SERVICE FACTOR									
		Worm RPM							
Ratio to 1		100	200	300	580	720	870	1150	1750
5	Me.HP	0.47	0.88	1.25	2.21	2.62	3.02	3.64	4.59
	Th.HP	0.40	0.73	1.04	1.84	2.18	2.52	3.03	3.43
	Efficiency	89	90	91	91	91	92	92	92
	O.T.	1,330	1,250	1,200	1,095	1,045	1,010	920	760
10	Me.HP	0.32	0.61	0.86	1.53	1.83	2.11	2.57	3.28
	Th.HP	0.25	0.47	0.66	1.18	1.40	1.63	1.98	2.53
	Efficiency	83	85	86	87	87	89	90	90
	O.T.	1,700	1,630	1,560	1,450	1,390	1,365	1,270	1,065
15	Me.HP	0.26	0.49	0.70	1.24	1.48	1.72	2.10	2.69
	Th.HP	0.18	0.33	0.47	0.83	0.99	1.15	1.40	1.79
	Efficiency	79	81	82	85	85	87	88	88
	O.T.	1,965	1,880	1,810	1,715	1,655	1,625	1,515	1,280
20	Me.HP	0.20	0.38	0.54	0.95	1.13	1.32	1.61	2.06
	Th.HP	0.13	0.25	0.36	0.63	0.76	0.88	1.07	1.38
	Efficiency	75	77	78	83	83	83	84	85
	O.T.	1,900	1,830	1,755	1,715	1,650	1,585	1,485	1,265
25	Me.HP	0.16	0.30	0.43	0.77	0.91	1.06	1.30	1.66
	Th.HP	0.11	0.20	0.29	0.51	0.61	0.71	0.87	1.11
	Efficiency	71	75	77	81	81	83	84	84
	O.T.	1,810	1,795	1,745	1,685	1,625	1,595	1,495	1,260
30	Me.HP	0.14	0.25	0.36	0.64	0.77	0.89	1.09	1.40
	Th.HP	0.09	0.17	0.24	0.43	0.51	0.59	0.73	0.93
	Efficiency	68	70	72	75	75	79	80	80
	O.T.	1,745	1,685	1,645	1,570	1,510	1,530	1,430	1,210
40	Me.HP	0.10	0.19	0.27	0.48	0.58	0.67	0.82	1.05
	Th.HP	0.07	0.13	0.18	0.32	0.38	0.45	0.55	0.70
	Efficiency	61	63	67	72	75	75	76	76
	O.T.	1,570	1,525	1,535	1,515	1,515	1,460	1,365	1,155
50	Me.HP	0.08	0.15	0.22	0.39	0.46	0.54	0.66	0.84
	Th.HP	0.05	0.10	0.15	0.26	0.31	0.36	0.44	0.56
	Efficiency	54	60	64	70	70	72	73	73
	O.T.	1,395	1,455	1,470	1,475	1,420	1,405	1,315	1,110
60	Me.HP	0.07	0.13	0.18	0.32	0.39	0.45	0.55	0.71
	Th.HP	0.05	0.09	0.12	0.22	0.26	0.30	0.37	0.47
	Efficiency	53	59	61	66	66	69	70	70
	O.T.	1,370	1,435	1,400	1,395	1,340	1,350	1,265	1,070

Key: Me.HP = Mech. Input Power (HP) Th.HP = Thermal Input Power - No Fan
O.T. = Output Torque (In. Lb.)





DIMENSIONS Size 25 heavyDRIVE "HvD" Series

BORE INCHES	GEARSHAFT NUMBER	KEYWAY SIZE
2.000*	25-S60-200	1/4 X 1/8
1.9375*	25-S60-115	1/4 X 1/8
1.6875*	25-S60-111	3/8 X 3/16
1.4375*	25-S60-107	3/8 X 3/16
1.250*	25-S60-104	1/4 X 1/8
1.1875*	25-S60-103	1/4 X 1/8

Size 25 Solid Shaft

Model HvD025 – Worm Over Gear net wt. 45 lbs

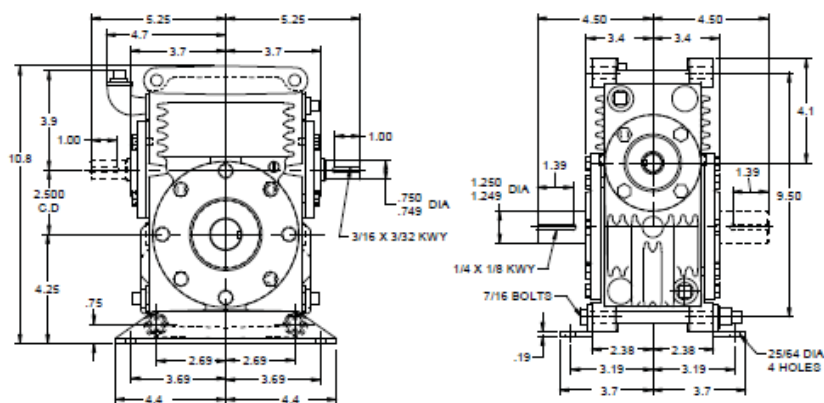

Hollow Shaft

net wt. 46 lbs

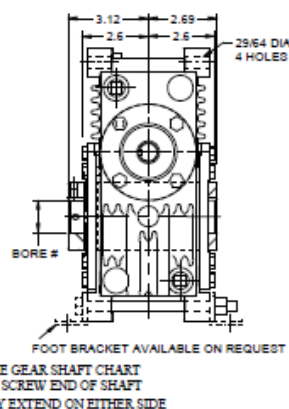

Model HvD025 – Worm Under Gear net wt. 45 lbs

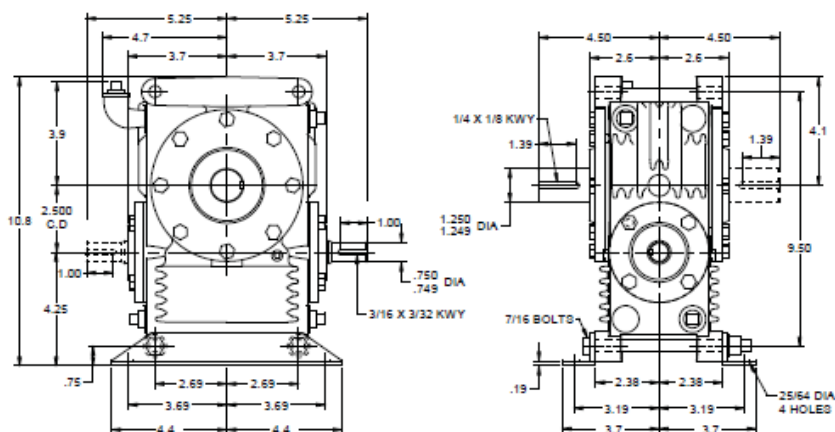

net wt. 46 lbs

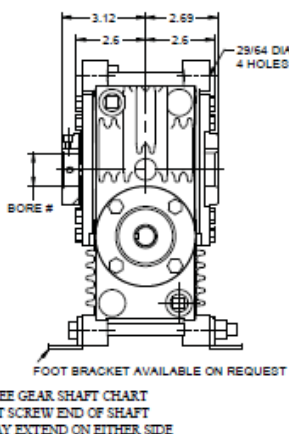

Model HvD025 – Vertical Gear Shaft

net wt. 45 lbs

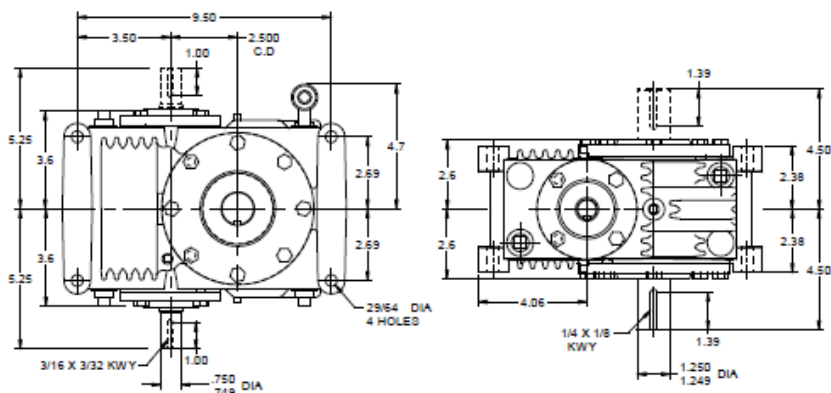

net wt. 46 lbs

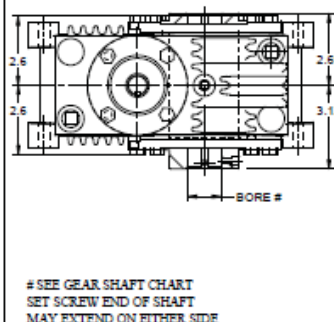

INPUT AND OUTPUT SHAFT MAY EXTEND ON EITHER SIDE OR MAY BE DOUBLE EXTENDED



RATINGS Size 25 heavyDRIVE "HvD" Series

Servo Worm Gearboxes Ultra Quiet Cast Iron Housing



AGMA Horsepower & Output Torque Ratings for 1.0 Service Factor									
Worm RPM									
Ratio to 1		100	200	300	580	720	870	1150	1750
5	Me.HP	0.94	1.72	2.45	4.22	4.95	5.60	6.56	8.23
	Th.HP	0.78	1.43	2.04	3.52	4.02	4.20	4.54	5.00
	Efficiency	89	90	91	91	91	92	92	92
	O.T.	2,625	2,440	2,345	2,090	1,975	1,870	1,655	1,365
10	Me.HP	0.65	1.19	1.69	2.95	3.49	3.97	4.72	5.93
	Th.HP	0.50	0.91	1.30	2.27	2.68	3.06	3.63	4.01
	Efficiency	83	85	86	87	87	89	90	90
	O.T.	3,375	3,180	3,050	2,790	2,655	2,560	2,330	1,925
15	Me.HP	0.52	0.96	1.37	2.39	2.83	3.24	3.86	4.83
	Th.HP	0.35	0.64	0.91	1.60	1.89	2.16	2.57	3.22
	Efficiency	79	81	82	85	85	87	88	88
	O.T.	3,895	3,675	3,535	3,320	3,165	3,060	2,795	2,300
20	Me.HP	0.40	0.74	1.05	1.83	2.17	2.48	2.96	3.71
	Th.HP	0.27	0.49	0.70	1.22	1.45	1.66	1.98	2.47
	Efficiency	75	77	78	83	83	83	84	85
	O.T.	3,770	3,575	3,435	3,310	3,155	2,990	2,730	2,270
25	Me.HP	0.32	0.59	0.84	1.48	1.75	2.00	2.39	2.99
	Th.HP	0.21	0.40	0.56	0.98	1.17	1.33	1.59	2.00
	Efficiency	71	75	77	81	81	83	84	84
	O.T.	3,595	3,505	3,415	3,250	3,100	3,010	2,750	2,265
30	Me.HP	0.27	0.50	0.71	1.24	1.46	1.68	2.00	2.52
	Th.HP	0.18	0.33	0.47	0.82	0.98	1.12	1.34	1.68
	Efficiency	68	70	72	75	75	79	80	80
	O.T.	3,460	3,290	3,210	3,025	2,885	2,880	2,640	2,180
40	Me.HP	0.20	0.37	0.53	0.93	1.10	1.26	1.51	1.90
	Th.HP	0.13	0.25	0.35	0.62	0.74	0.84	1.01	1.26
	Efficiency	61	63	67	72	75	75	76	76
	O.T.	3,115	2,970	3,000	2,920	2,900	2,745	2,515	2,080
50	Me.HP	0.16	0.30	0.43	0.75	0.89	1.01	1.21	1.52
	Th.HP	0.11	0.20	0.28	0.50	0.59	0.68	0.81	1.01
	Efficiency	54	60	64	70	70	72	73	73
	O.T.	2,765	2,835	2,875	2,845	2,715	2,645	2,420	2,000
60	Me.HP	0.14	0.25	0.36	0.62	0.74	0.85	1.01	1.27
	Th.HP	0.09	0.17	0.24	0.42	0.49	0.56	0.67	0.85
	Efficiency	53	59	61	66	66	69	70	70
	O.T.	2,715	2,795	2,740	2,685	2,560	2,535	2,330	1,920

Key: Me.HP = Mech. Input Power (HP) Th.HP = Thermal Input Power - No Fan
O.T. = Output Torque (In. Lb.)





DIMENSIONS Size 30 heavyDRIVE "HvD" Series

BORE INCHES	GEARSHAFT NUMBER	KEYWAY SIZE
2.500*	30-S60-208	3/8 X 3/16
2.4375*	30-S60-207	3/8 X 3/16
2.1875*	30-S60-203	1/2 X 1/4
1.9375*	30-S60-115	1/2 X 1/4
1.6875*	30-S60-111	3/8 X 3/16
1.500*	30-S60-108	3/8 X 3/16

Solid Shaft

Model HvD030 – Worm Over Gear net wt. 73 lbs

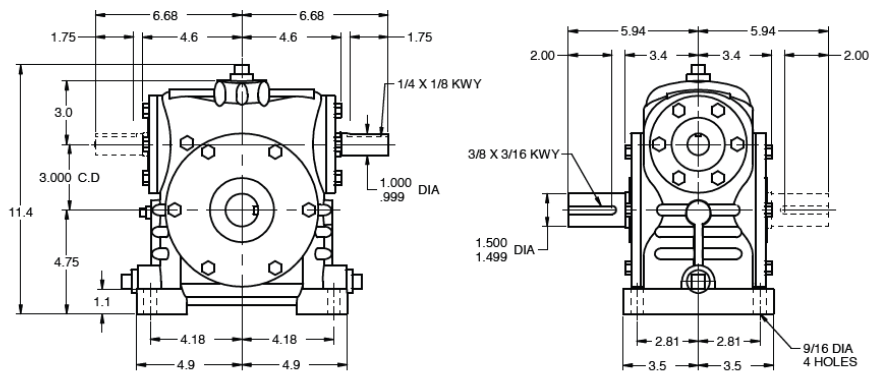

Hollow Shaft

net wt. 92 lbs

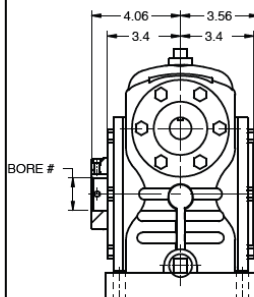

SEE GEAR SHAFT CHART
SET SCREW END OF SHAFT
MAY EXTEND ON EITHER SIDE

Model HvD030 – Worm Under Gear net wt. 83 lbs

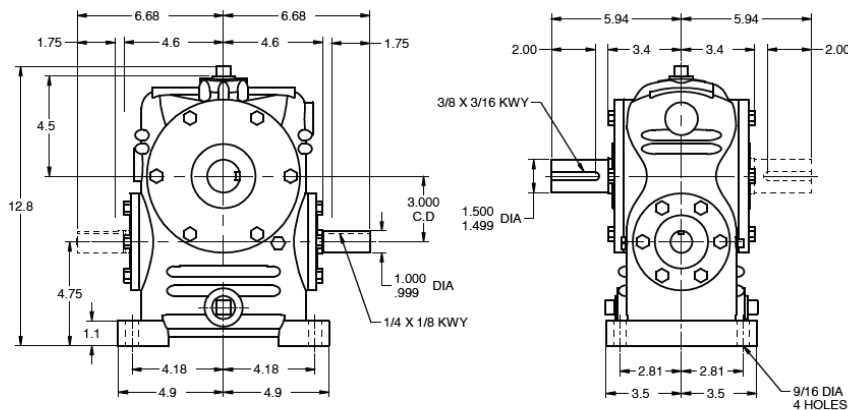

net wt. 90 lbs

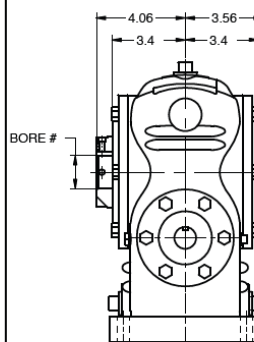

SEE GEAR SHAFT CHART
SET SCREW END OF SHAFT
MAY EXTEND ON EITHER SIDE

Model HvD030 – Vertical Gear Shaft

net wt. 74 lbs

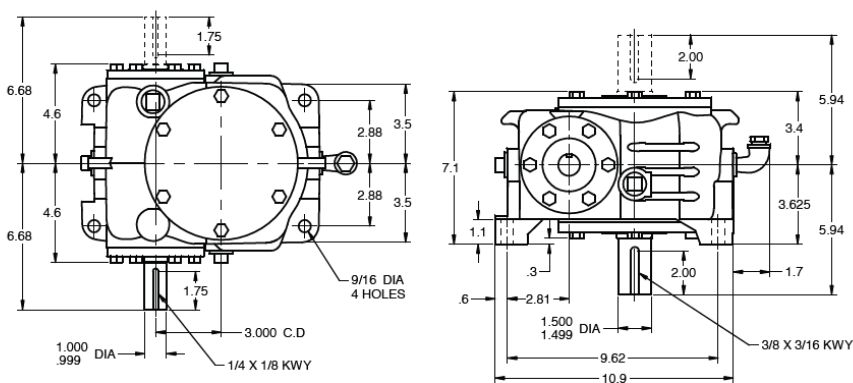

net wt. 89 lbs

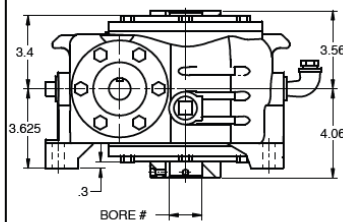

SEE GEAR SHAFT CHART
SET SCREW END OF SHAFT
MAY EXTEND ON EITHER SIDE

INPUT AND OUTPUT SHAFT MAY EXTEND ON EITHER SIDE OR MAY BE DOUBLE EXTENDED



RATINGS Size 30 heavyDRIVE "HvD" Series

Servo Worm Gearboxes Ultra Quiet Cast Iron Housing



AGMA Horsepower & Output Torque Ratings for 1.0 Service Factor									
Worm RPM									
Ratio to 1		100	200	300	580	720	870	1150	1750
5	Me.HP	1.66	3.03	4.32	7.26	8.37	9.34	10.80	13.58
	Th.HP	1.37	2.03	2.55	3.63	4.06	4.25	4.59	5.05
	Th.HP Fan								
	Efficiency	89	90	91	91	91	92	92	92
	O.T.	4,645	4,300	4,130	3,590	3,335	3,115	2,725	2,250
10	Me.HP	1.15	2.11	3.00	5.17	6.05	6.84	8.03	10.05
	Th.HP	0.88	1.62	2.31	3.19	3.38	3.61	3.80	4.05
	Th.HP Fan								
	Efficiency	83	85	86	87	87	89	90	90
	O.T.	6,005	5,650	5,425	4,890	4,610	4,415	3,965	3,255
15	Me.HP	0.93	1.71	2.43	4.20	4.93	5.59	6.57	8.22
	Th.HP	0.62	1.14	1.62	2.71	2.87	2.99	3.12	3.33
	Th.HP Fan								
	Efficiency	79	81	82	85	85	87	88	88
	O.T.	6,930	6,530	6,275	5,825	5,500	5,285	4,755	3,910
20	Me.HP	0.71	1.31	1.86	3.23	3.79	4.30	5.07	6.34
	Th.HP	0.47	0.87	1.24	2.15	2.53	2.73	2.81	2.90
	Th.HP Fan								
	Efficiency	75	77	78	83	83	83	84	85
	O.T.	6,730	6,350	6,105	5,820	5,505	5,175	4,670	3,880
25	Me.HP	0.57	1.06	1.50	2.60	3.05	3.46	4.09	5.11
	Th.HP	0.38	0.70	1.00	1.73	2.03	2.29	2.34	2.43
	Th.HP Fan								
	Efficiency	71	75	77	81	81	83	84	84
	O.T.	6,415	6,235	6,070	5,715	5,410	5,210	4,705	3,865
30	Me.HP	0.48	0.88	1.26	2.18	2.56	2.91	3.43	4.29
	Th.HP	0.32	0.59	0.84	1.45	1.70	1.94	2.11	2.17
	Th.HP Fan								
	Efficiency	68	70	72	75	75	79	80	80
	O.T.	6,175	5,850	5,705	5,335	5,035	4,995	4,515	3,710
40	Me.HP	0.36	0.67	0.95	1.64	1.93	2.19	2.58	3.23
	Th.HP	0.24	0.44	0.63	1.09	1.28	1.46	1.72	1.93
	Th.HP Fan								
	Efficiency	61	63	67	72	75	75	76	76
	O.T.	5,555	5,280	5,325	5,135	5,060	4,755	4,300	3,535
50	Me.HP	0.29	0.53	0.76	1.32	1.55	1.76	2.07	2.60
	Th.HP	0.19	0.36	0.51	0.88	1.03	1.17	1.38	1.73
	Th.HP Fan								
	Efficiency	54	60	64	70	70	72	73	73
	O.T.	4,930	5,045	5,100	5,015	4,745	4,585	4,140	3,415
60	Me.HP	0.24	0.45	0.63	1.10	1.29	1.47	1.73	2.17
	Th.HP	0.16	0.30	0.42	0.73	0.86	0.98	1.15	1.44
	Th.HP Fan								
	Efficiency	53	59	61	66	66	69	70	70
	O.T.	4,845	4,965	4,865	4,735	4,480	4,400	3,975	3,275

Key: Me.HP = Mech. Input Power (HP) Th.HP = Thermal Input Power - No Fan
O.T. = Output Torque (In. Lb.) Th.HP Fan = Thermal Input Power - Fan





DIMENSIONS Size 35 heavyDRIVE "HvD" Series

BORE INCHES	GEARSHAFT NUMBER	KEYWAY SIZE
2.750*	35-S60-212	3/8 X 3/16
2.6875*	35-S60-211	3/8 X 3/16
2.500*	35-S60-208	3/8 X 3/16
2.4375*	35-S60-207	5/8 X 5/16
2.1875*	35-S60-203	1/2 X 1/4
1.9375*	35-S60-115	1/2 X 1/4
1.6875*	35-S60-111	3/8 X 3/16

Solid Shaft

Model HvD035 – Worm Over Gear net wt. 122 lbs

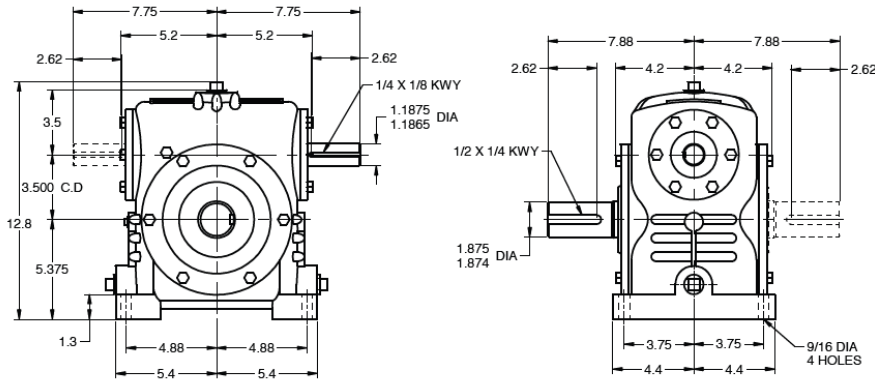

Hollow Shaft

net wt. 126 lbs

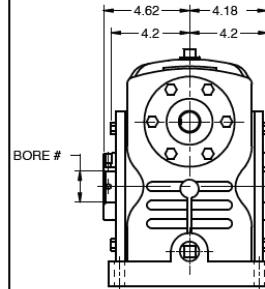

SEE GEAR SHAFT CHART
SET SCREW END OF SHAFT
MAY EXTEND ON EITHER SIDE

Model HvD035 – Worm Under Gear net wt. 134 lbs

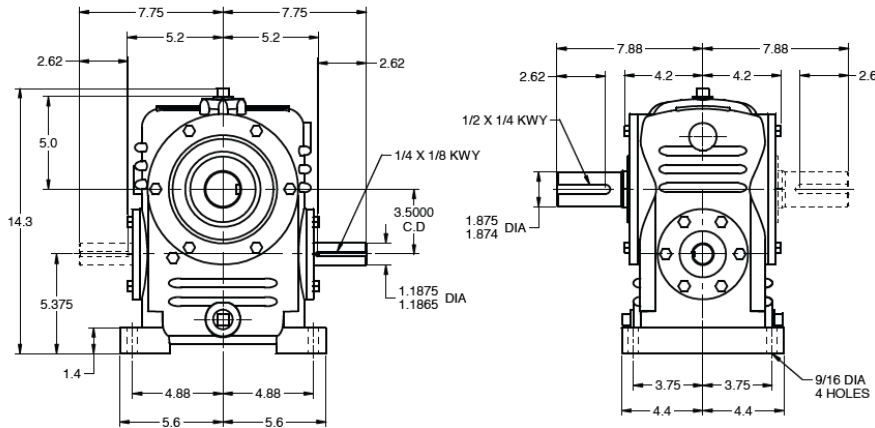

net wt. 140 lbs

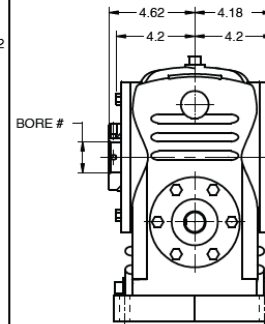

SEE GEAR SHAFT CHART
SET SCREW END OF SHAFT
MAY EXTEND ON EITHER SIDE

Model HvD035 – Vertical Gear Shaft

net wt. 120 lbs

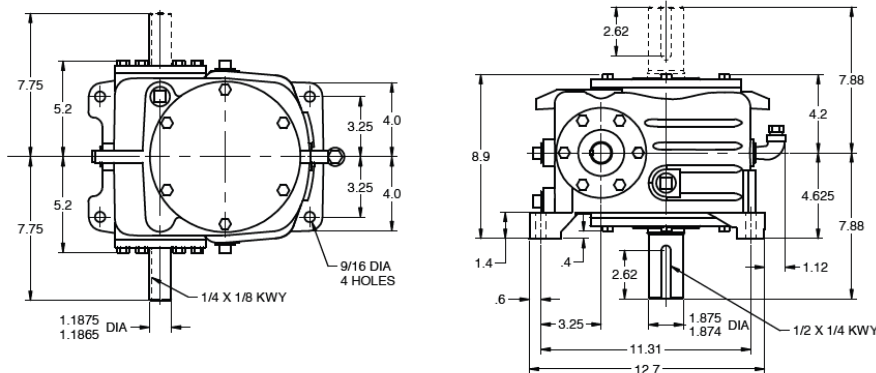

net wt. 123 lbs

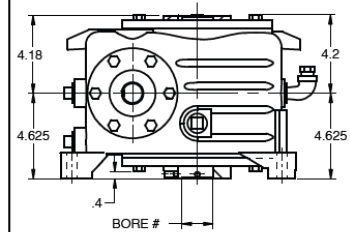

SEE GEAR SHAFT CHART
SET SCREW END OF SHAFT
MAY EXTEND ON EITHER SIDE

INPUT AND OUTPUT SHAFT MAY EXTEND ON EITHER SIDE OR MAY BE DOUBLE EXTENDED



RATINGS Size 35 heavyDRIVE “HvD” Series

Servo Worm Gearboxes Ultra Quiet Cast Iron Housing



AGMA Horsepower & Output Torque Ratings for 1.0 Service Factor									
Worm RPM									
Ratio to 1		100	200	300	580	720	870	1150	1750
5	Me.HP	3.06	5.59	7.91	12.97	14.79	16.37	19.11	23.54
	Th.HP	2.55	4.41	5.68	8.09	9.06	9.77	10.55	11.61
	Th.HP Fan	3.06	5.59	7.91	12.97	14.79	16.37	19.11	23.21
	Efficiency	89	90	91	91	91	92	92	92
	O.T.	8,595	7,930	7,565	6,410	5,890	5,455	4,815	3,900
10	Me.HP	2.12	3.88	5.53	9.30	10.73	12.00	13.92	17.37
	Th.HP	1.63	2.98	4.26	6.57	7.19	7.67	8.25	8.80
	Th.HP Fan	2.12	3.88	5.53	9.30	10.73	12.00	13.92	17.37
	Efficiency	83	85	86	87	87	89	90	90
	O.T.	11,095	10,385	9,995	8,795	8,170	7,735	6,865	5,630
15	Me.HP	1.71	3.14	4.48	7.56	8.76	9.81	11.40	14.27
	Th.HP	1.14	2.09	2.98	5.04	5.84	6.54	7.60	6.95
	Th.HP Fan	1.71	3.14	4.48	7.56	8.76	9.81	11.40	13.91
	Efficiency	79	81	82	85	85	87	88	88
	O.T.	12,805	12,025	11,565	10,470	9,775	9,275	8,245	6,785
20	Me.HP	1.31	2.40	3.43	5.80	6.73	7.55	8.76	10.98
	Th.HP	0.88	1.60	2.29	3.87	4.48	5.03	5.58	5.82
	Th.HP Fan	1.31	2.40	3.43	5.80	6.73	7.55	8.76	10.98
	Efficiency	75	77	78	83	83	83	84	85
	O.T.	12,410	11,655	11,235	10,465	9,775	9,080	8,065	6,725
25	Me.HP	1.06	1.94	2.77	4.68	5.43	6.10	7.07	8.84
	Th.HP	0.71	1.29	1.84	3.12	3.62	4.06	4.64	4.82
	Th.HP Fan	1.06	1.94	2.77	4.68	5.43	6.10	7.07	8.84
	Efficiency	71	75	77	81	81	83	84	84
	O.T.	11,830	11,445	11,185	10,305	9,625	9,165	8,140	6,690
30	Me.HP	0.89	1.62	2.32	3.93	4.55	5.11	5.93	7.41
	Th.HP	0.59	1.08	1.54	2.62	3.03	3.41	3.95	4.17
	Th.HP Fan	0.89	1.62	2.32	3.93	4.55	5.11	5.93	7.41
	Efficiency	68	70	72	75	75	79	80	80
	O.T.	11,390	10,740	10,515	9,610	8,960	8,770	7,795	6,405
40	Me.HP	0.67	1.22	1.74	2.96	3.42	3.85	4.47	5.57
	Th.HP	0.44	0.81	1.16	1.97	2.28	2.57	2.98	3.64
	Th.HP Fan	0.67	1.22	1.74	2.96	3.42	3.85	4.47	5.57
	Efficiency	61	63	67	72	75	75	76	76
	O.T.	10,245	9,695	9,810	9,250	8,980	8,365	7,445	6,100
50	Me.HP	0.53	0.98	1.40	2.37	2.75	3.09	3.59	4.50
	Th.HP	0.36	0.65	0.93	1.58	1.83	2.06	2.39	3.00
	Th.HP Fan	0.53	0.98	1.40	2.37	2.75	3.09	3.59	4.50
	Efficiency	54	60	64	70	70	72	73	73
	O.T.	9,095	9,255	9,395	9,020	8,425	8,055	7,170	5,915
60	Me.HP	0.45	0.82	1.17	1.98	2.29	2.58	2.99	3.75
	Th.HP	0.30	0.54	0.78	1.32	1.53	1.72	1.99	2.50
	Th.HP Fan	0.45	0.82	1.17	1.98	2.29	2.58	2.99	3.75
	Efficiency	53	59	61	66	66	69	70	70
	O.T.	8,940	9,115	8,970	8,515	7,955	7,730	6,885	5,680

Key: Me.HP = Mech. Input Power (HP) Th.HP = Thermal Input Power - No Fan
 O.T. = Output Torque (In. Lb.) Th.HP Fan = Thermal Input Power - Fan





DIMENSIONS Size 40 heavyDRIVE "HvD" Series

BORE INCHES	GEARSHAFT NUMBER	KEYWAY SIZE
2.9375*	40-S60-215	5/8 X 5/16
2.6875*	40-S60-211	5/8 X 5/16
2.4375*	40-S60-207	5/8 X 5/16
2.1875*	40-S60-203	5/8 X 5/16

Solid Shaft

Model HvD040 – Worm Over Gear net wt. 175 lbs

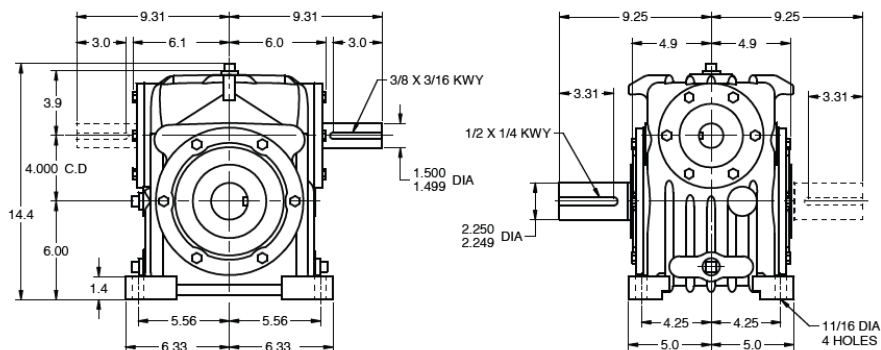

Hollow Shaft

net wt. 185 lbs

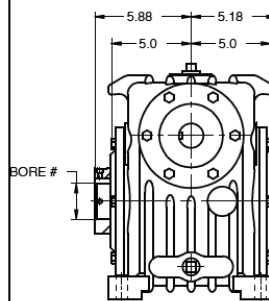

SEE GEAR SHAFT CHART
SET SCREW END OF SHAFT
MAY EXTEND ON EITHER SIDE

Model HvD040 – Worm Under Gear net wt. 187 lbs

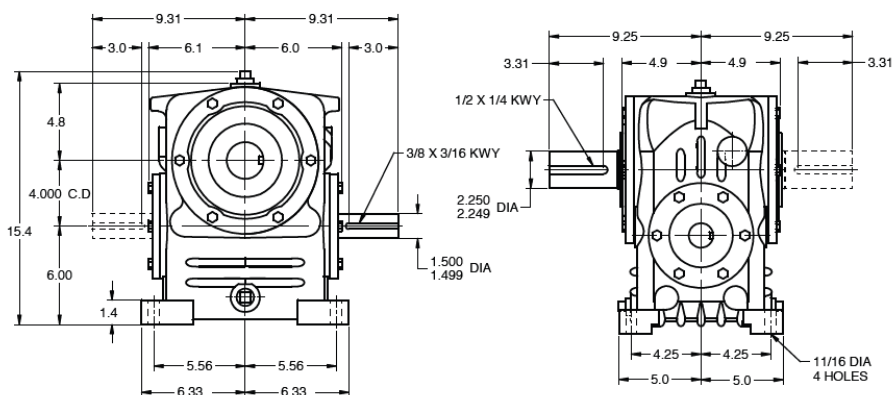

net wt. 197 lbs

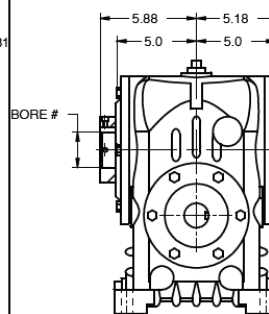

SEE GEAR SHAFT CHART
SET SCREW END OF SHAFT
MAY EXTEND ON EITHER SIDE

Model HvD040 – Vertical Gear Shaft

net wt. 170 lbs

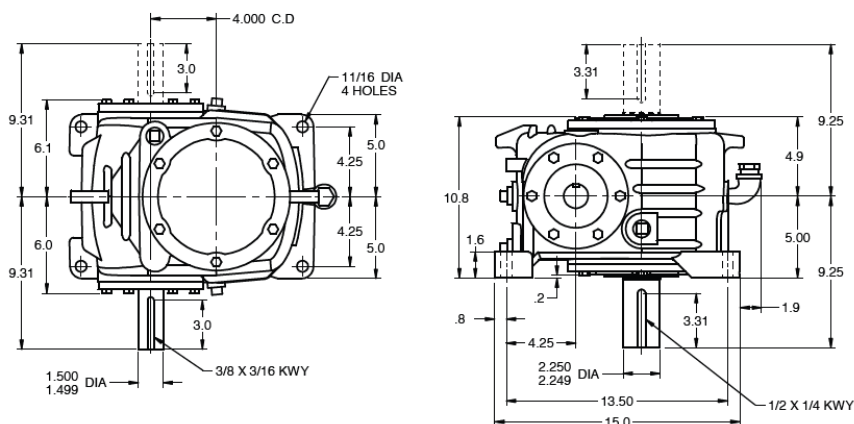

net wt. 180 lbs

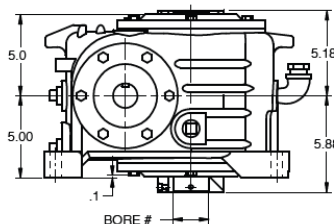

SEE GEAR SHAFT CHART
SET SCREW END OF SHAFT
MAY EXTEND ON EITHER SIDE

INPUT AND OUTPUT SHAFT MAY EXTEND ON EITHER SIDE OR MAY BE DOUBLE EXTENDED



RATINGS Size 40 heavyDRIVE "HvD" Series

Servo Worm Gearboxes Ultra Quiet Cast Iron Housing



AGMA HORSEPOWER & OUTPUT TORQUE RATINGS FOR 1.0 SERVICE FACTOR									
Worm RPM									
Ratio to 1		100	200	300	580	720	870	1150	1750
5	Me.HP	4.39	8.03	11.27	17.98	20.30	22.40	25.99	31.84
	Th.HP	3.53	5.35	6.88	9.80	10.97	11.83	12.78	14.06
	Th.HP Fan	4.39	8.03	11.27	17.98	20.30	22.40	25.56	28.12
	Efficiency	92	93	94	94	94	95	95	95
	O.T.	12,715	11,770	11,130	9,180	8,350	7,710	6,765	5,445
10	Me.HP	3.06	5.58	7.92	13.07	14.96	16.59	19.30	23.88
	Th.HP	2.35	4.29	5.80	7.96	8.71	9.30	9.99	10.66
	Th.HP Fan	3.06	5.58	7.92	13.07	14.96	16.59	19.30	21.33
	Efficiency	86	88	89	90	90	92	93	93
	O.T.	16,570	15,475	14,800	12,780	11,785	11,055	9,835	8,000
15	Me.HP	2.47	4.51	6.42	10.65	12.22	13.57	15.73	19.58
	Th.HP	1.65	3.01	4.28	7.10	8.15	7.46	7.89	8.42
	Th.HP Fan	2.47	4.51	6.42	10.65	12.22	13.57	15.73	16.85
	Efficiency	82	84	85	88	89	90	91	91
	O.T.	19,160	17,920	17,180	15,270	14,280	13,270	11,770	9,625
20	Me.HP	1.90	3.46	4.91	8.17	9.39	10.45	12.10	15.08
	Th.HP	1.26	2.31	3.28	5.45	6.19	6.50	6.76	7.05
	Th.HP Fan	1.90	3.46	4.91	8.17	9.39	10.45	12.10	14.10
	Efficiency	78	80	81	86	86	86	87	88
	O.T.	18,635	17,430	16,720	15,275	14,130	13,020	11,535	9,555
25	Me.HP	1.53	2.79	3.96	6.60	7.58	8.44	9.80	12.14
	Th.HP	1.02	1.86	2.64	4.40	5.05	5.47	5.62	5.84
	Th.HP Fan	1.53	2.79	3.96	6.60	7.58	8.44	9.80	11.69
	Efficiency	74	78	80	84	84	86	87	87
	O.T.	17,800	17,135	16,655	15,050	13,930	13,140	11,675	9,510
30	Me.HP	1.28	2.34	3.32	5.54	6.36	7.07	8.23	10.21
	Th.HP	0.85	1.56	2.21	3.69	4.24	4.71	4.91	5.05
	Th.HP Fan	1.28	2.34	3.32	5.54	6.36	7.07	8.23	10.11
	Efficiency	71	73	75	78	81	82	83	83
	O.T.	17,170	16,125	15,700	14,080	13,535	12,595	11,230	9,155
40	Me.HP	0.96	1.76	2.50	4.17	4.79	5.33	6.19	7.68
	Th.HP	0.64	1.17	1.67	2.78	3.19	3.55	4.13	4.41
	Th.HP Fan	0.96	1.76	2.50	4.17	4.79	5.33	6.19	7.68
	Efficiency	64	66	70	75	76	78	79	79
	O.T.	15,540	14,620	14,715	13,575	12,730	12,045	10,720	8,735
50	Me.HP	0.77	1.41	2.01	3.34	3.84	4.28	4.97	6.16
	Th.HP	0.52	0.94	1.34	2.23	2.56	2.85	3.31	3.92
	Th.HP Fan	0.77	1.41	2.01	3.34	3.84	4.28	4.97	6.16
	Efficiency	57	63	67	73	74	75	76	76
	O.T.	13,880	13,990	14,125	13,250	12,430	11,610	10,340	8,425
60	Me.HP	0.64	1.18	1.68	2.79	3.20	3.57	4.14	5.14
	Th.HP	0.43	0.78	1.12	1.86	2.14	2.38	2.76	3.43
	Th.HP Fan	0.64	1.18	1.68	2.79	3.20	3.57	4.14	5.14
	Efficiency	56	62	64	69	71	72	73	73
	O.T.	13,655	13,790	13,510	12,540	11,940	11,160	9,945	8,105

Key: Me.HP = Mech. Input Power (HP)
O.T. = Output Torque (In. Lb.)

Th.HP = Thermal Input Power - No Fan
Th.HP Fan = Thermal Input Power - Fan





DIMENSIONS Size 50 heavyDRIVE "HvD" Series

BORE INCHES	GEARSHAFT NUMBER	KEYWAY SIZE
3.4375*	50-S60-307	5/8 X 5/16
3.1875*	50-S60-303	5/8 X 5/16
2.750*	50-S60-212	5/8 X 5/16

Solid Shaft

Model HvD050 – Worm Over Gear net wt. 290 lbs

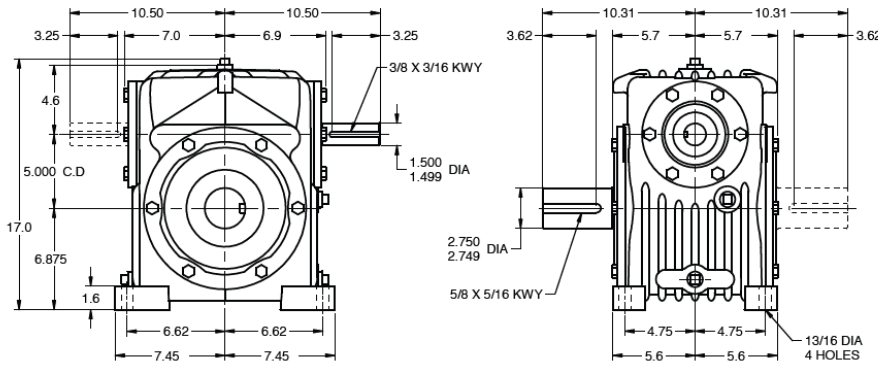

Hollow Shaft

net wt. 302 lbs

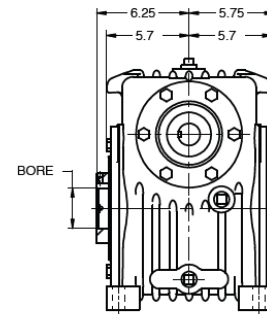

SEE GEAR SHAFT CHART
SET SCREW END OF SHAFT
MAY EXTEND ON EITHER SIDE

Model HvD050 – Worm Under Gear net wt. 305 lbs

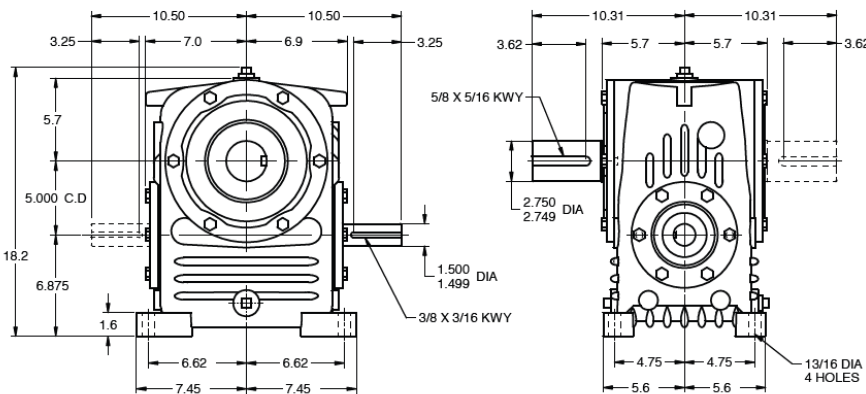

net wt. 317 lbs

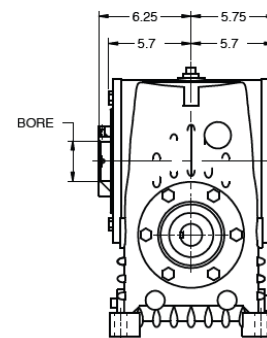

SEE GEAR SHAFT CHART
SET SCREW END OF SHAFT
MAY EXTEND ON EITHER SIDE

Model HvD050 – Vertical Gear Shaft

net wt. 295 lbs

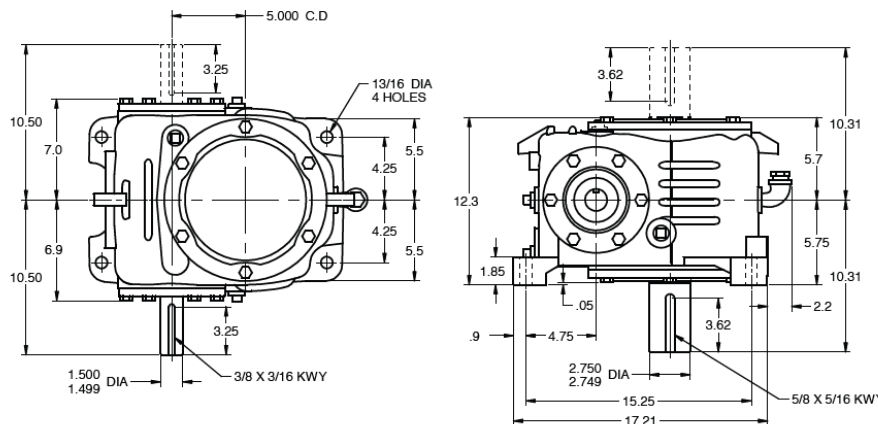

net wt. 307 lbs

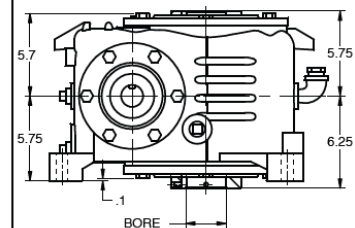

SEE GEAR SHAFT CHART
SET SCREW END OF SHAFT
MAY EXTEND ON EITHER SIDE

INPUT AND OUTPUT SHAFT MAY EXTEND ON EITHER SIDE OR MAY BE DOUBLE EXTENDED



RATINGS Size 50 heavyDRIVE "HvD" Series

Servo Worm Gearboxes Ultra Quiet Cast Iron Housing



AGMA HORSEPOWER & OUTPUT TORQUE RATINGS FOR 1.0 SERVICE FACTOR									
Worm RPM									
Ratio to 1		100	200	300	580	720	870	1150	1750
5	Me.HP	8.72	15.91	22.03	33.96	37.97	42.19	48.26	58.80
	Th.HP	4.41	6.67	8.59	12.24	13.70	14.77	15.96	17.55
	Th.HP Fan	8.72	13.35	17.18	24.48	27.39	29.54	31.91	35.10
	Efficiency	92	93	94	94	94	95	95	95
	O.T.	25,270	23,305	21,750	17,340	15,620	14,515	12,560	10,060
10	Me.HP	6.02	11.02	15.43	24.48	27.54	30.43	35.34	43.33
	Th.HP	3.93	5.64	7.24	9.93	10.87	11.60	12.47	13.31
	Th.HP Fan	6.02	11.02	14.48	19.86	21.75	23.21	24.95	26.62
	Efficiency	86	88	89	90	90	92	93	93
	O.T.	32,630	30,555	28,850	23,930	21,690	20,275	18,010	14,510
15	Me.HP	4.87	8.93	12.51	20.00	22.53	24.86	28.85	35.33
	Th.HP	3.25	5.95	6.08	8.22	8.81	9.31	9.85	10.52
	Th.HP Fan	4.87	8.93	12.16	16.44	17.61	18.63	19.69	21.03
	Efficiency	82	84	85	88	89	90	91	91
	O.T.	37,735	35,450	33,500	28,675	26,325	24,310	21,575	17,365
20	Me.HP	3.72	6.83	9.58	15.36	17.27	19.06	22.19	27.33
	Th.HP	2.48	4.36	5.37	7.29	7.72	8.11	8.43	8.80
	Th.HP Fan	3.72	6.83	9.58	14.59	15.45	16.22	16.87	17.60
	Efficiency	78	80	81	86	86	86	87	88
	O.T.	36,590	34,415	32,600	28,695	25,995	23,740	21,155	17,315
25	Me.HP	3.00	5.51	7.73	12.40	13.98	15.43	17.93	22.09
	Th.HP	2.00	3.67	4.63	6.33	6.60	6.82	7.02	7.29
	Th.HP Fan	3.00	5.51	7.73	12.40	13.21	13.64	14.04	14.59
	Efficiency	74	78	80	84	84	86	87	87
	O.T.	35,005	33,840	32,480	28,280	25,690	24,030	21,365	17,300
30	Me.HP	2.52	4.62	6.49	10.41	11.74	12.97	15.07	18.51
	Th.HP	1.68	3.08	4.01	5.46	5.75	5.97	6.13	6.31
	Th.HP Fan	2.52	4.62	6.49	10.41	11.50	11.95	12.25	12.62
	Efficiency	71	73	75	78	81	82	83	83
	O.T.	33,765	31,840	30,670	26,460	24,965	23,100	20,555	16,595
40	Me.HP	1.89	3.48	4.88	7.83	8.83	9.75	11.33	13.92
	Th.HP	1.26	2.32	3.25	5.22	4.90	5.14	5.32	5.50
	Th.HP Fan	1.89	3.48	4.88	7.83	8.83	9.75	10.64	11.00
	Efficiency	64	66	70	75	76	78	79	79
	O.T.	30,520	28,915	28,700	25,515	23,485	22,035	19,615	15,835
50	Me.HP	1.52	2.79	3.92	6.28	7.10	7.82	9.12	11.17
	Th.HP	1.01	1.86	2.61	3.84	4.06	4.27	4.57	4.89
	Th.HP Fan	1.52	2.79	3.92	6.28	7.10	7.82	9.12	9.78
	Efficiency	57	63	67	73	74	75	76	76
	O.T.	27,255	27,675	27,545	24,900	22,985	21,240	18,980	15,275
60	Me.HP	1.27	2.33	3.27	5.25	5.92	6.53	7.61	9.32
	Th.HP	0.84	1.55	2.18	3.39	3.58	3.79	4.13	4.40
	Th.HP Fan	1.27	2.33	3.27	5.25	5.92	6.53	7.61	8.80
	Efficiency	56	62	64	69	71	72	73	73
	O.T.	26,810	27,270	26,345	23,620	22,085	20,420	18,255	14,695
70	Me.HP	1.09	2.00	2.80	4.51	5.08	5.60	6.53	8.00
	Th.HP	0.72	1.33	1.87	3.00	3.36	3.51	3.81	3.91
	Th.HP Fan	1.09	2.00	2.80	4.51	5.08	5.60	6.53	7.81
	Efficiency	55	61	63	68	70	71	72	72
	O.T.	26,365	26,870	25,970	23,310	21,800	20,165	18,030	14,510

Key: Me.HP = Mech. Input Power (HP)
O.T. = Output Torque (In. Lb.)

Th.HP = Thermal Input Power - No Fan
Th.HP Fan = Thermal Input Power - Fan





DIMENSIONS Size 60 heavyDRIVE "HvD" Series

BORE INCHES	GEARSHAFT NUMBER	KEYWAY SIZE
3.9375*	60-S60-315	3/4 X 3/8
3.4375*	60-S60-307	3/4 X 3/8
2.9375*	60-S60-215	3/4 X 3/8

Solid Shaft

Model HvD060 – Worm Over Gear net wt. 388 lbs

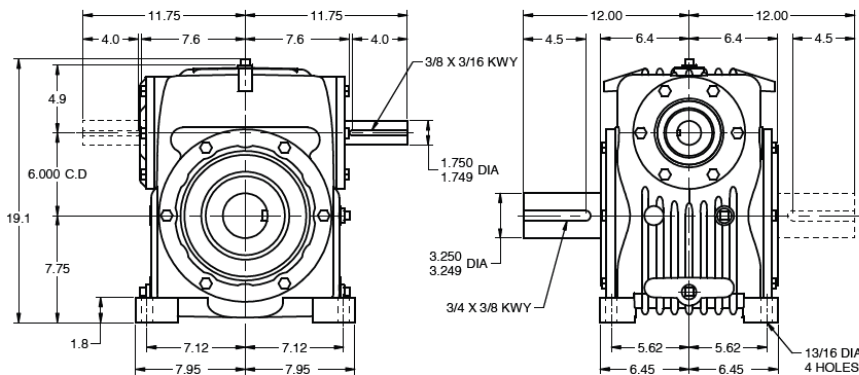

Hollow Shaft

net wt. 403 lbs

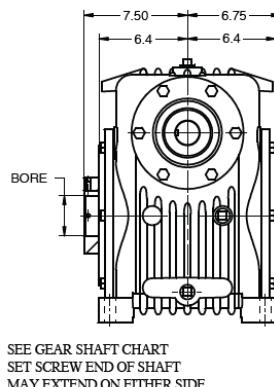

Model HvD060 – Worm Under Gear net wt. 396 lbs

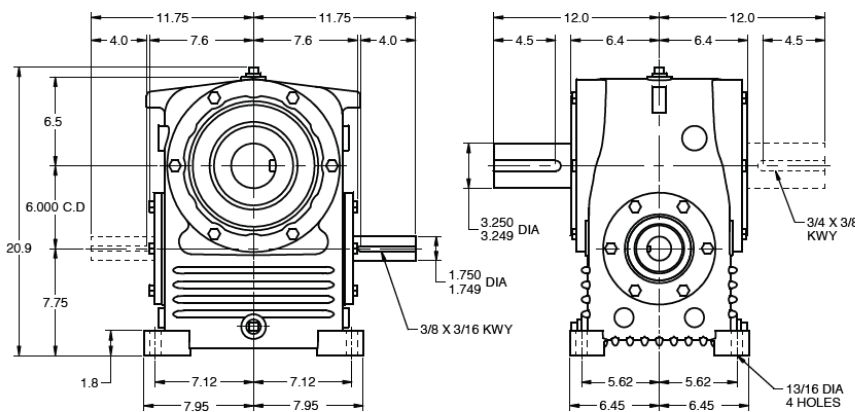

net wt. 411 lbs

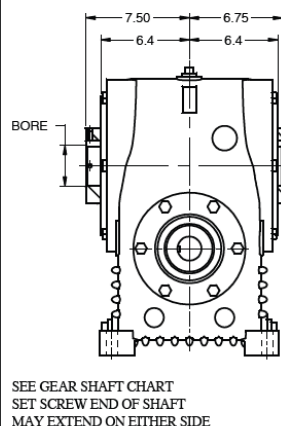

Model HvD060 – Vertical Gear Shaft

net wt. 418 lbs

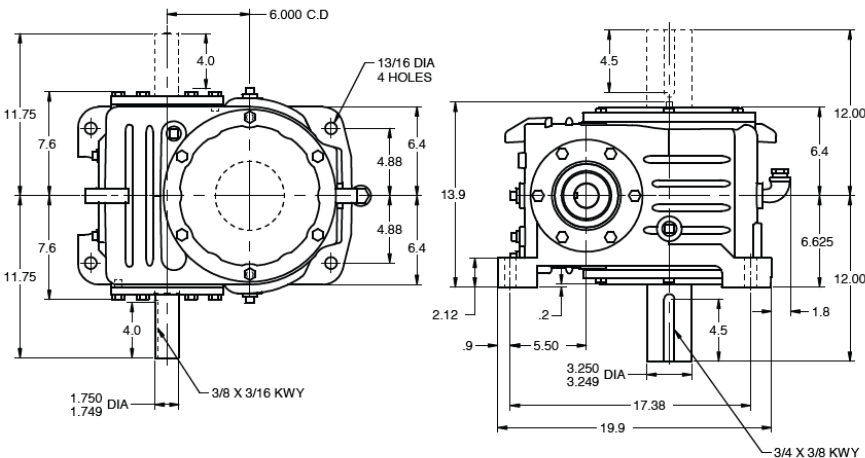

net wt. 433 lbs

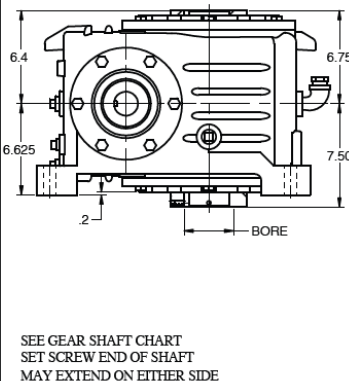

INPUT AND OUTPUT SHAFT MAY EXTEND ON EITHER SIDE OR MAY BE DOUBLE EXTENDED



RATINGS Size 60 heavyDRIVE “HvD” Series

Servo Worm Gearboxes Ultra Quiet Cast Iron Housing



AGMA HORSEPOWER & OUTPUT TORQUE RATINGS FOR 1.0 SERVICE FACTOR									
		Worm RPM							
Ratio to 1		100	200	300	580	720	870	1150	1750
5	Me.HP	13.31	24.04	32.79	48.28	54.33	59.84	68.35	79.85
	Th.HP	6.28	9.51	12.24	17.44	19.51	21.04	22.73	25.01
	Th.HP Fan	12.57	19.02	24.48	34.87	39.03	42.09	45.47	50.01
	Efficiency	92	93	94	94	94	95	95	95
	O.T.	38,575	35,215	32,365	24,650	22,345	20,585	17,785	13,660
10	Me.HP	9.23	16.82	23.23	35.27	39.53	43.82	50.62	60.62
	Th.HP	5.59	8.04	10.32	14.15	15.49	16.53	17.77	18.97
	Th.HP Fan	9.23	16.07	20.64	28.30	30.99	33.07	35.54	37.93
	Efficiency	86	88	89	90	90	92	93	93
	O.T.	49,995	46,630	43,425	34,480	31,135	29,195	25,790	20,295
15	Me.HP	7.46	13.63	18.87	28.85	32.30	35.75	41.22	49.71
	Th.HP	4.97	7.00	8.66	11.71	12.54	13.27	14.03	14.98
	Th.HP Fan	7.46	13.63	17.32	23.42	25.09	26.54	28.06	29.96
	Efficiency	82	84	85	88	89	90	91	91
	O.T.	57,820	54,100	50,535	41,370	37,735	34,945	30,825	24,430
20	Me.HP	5.72	10.44	14.46	22.17	24.76	27.57	31.62	38.50
	Th.HP	3.82	6.21	7.65	10.39	11.00	11.55	12.02	12.54
	Th.HP Fan	5.72	10.44	14.46	20.78	22.01	23.11	24.03	25.08
	Efficiency	78	80	81	86	86	86	87	88
	O.T.	56,250	52,615	49,185	41,415	37,270	34,345	30,145	24,395
25	Me.HP	4.61	8.42	11.67	17.94	20.05	22.27	25.55	31.01
	Th.HP	3.07	5.28	6.60	9.02	9.41	9.72	10.00	10.39
	Th.HP Fan	4.61	8.42	11.67	17.94	18.82	19.44	20.00	20.78
	Efficiency	74	78	80	84	84	86	87	87
	O.T.	53,725	51,740	49,000	40,925	36,850	34,680	30,450	24,280
30	Me.HP	3.87	7.06	9.77	15.03	16.85	18.66	21.41	26.09
	Th.HP	2.58	4.40	5.72	7.77	8.20	8.51	8.73	8.99
	Th.HP Fan	3.87	7.06	9.77	15.03	16.39	17.02	17.46	17.98
	Efficiency	71	73	75	78	81	82	83	83
	O.T.	51,910	48,685	46,185	38,205	35,825	33,245	29,210	23,385
40	Me.HP	2.91	5.31	7.35	11.33	12.67	14.07	16.10	19.62
	Th.HP	1.93	3.54	4.76	7.55	6.98	7.32	7.58	7.84
	Th.HP Fan	2.91	5.31	7.35	11.33	12.67	14.07	15.16	15.67
	Efficiency	64	66	70	75	76	78	79	79
	O.T.	46,920	44,135	43,225	36,925	33,700	31,800	27,875	22,320
50	Me.HP	2.33	4.26	5.90	9.09	10.16	11.29	12.92	15.74
	Th.HP	1.55	2.83	3.90	5.47	5.79	6.09	6.50	6.97
	Th.HP Fan	2.33	4.26	5.90	9.09	10.16	11.29	12.92	13.93
	Efficiency	57	63	67	73	74	75	76	76
	O.T.	41,900	42,245	41,480	36,035	32,905	30,660	26,890	21,530
60	Me.HP	1.95	3.55	4.92	7.58	8.48	9.42	10.78	13.13
	Th.HP	1.29	2.36	3.28	4.83	5.10	5.40	5.89	6.27
	Th.HP Fan	1.95	3.55	4.92	7.58	8.48	9.42	10.78	12.54
	Efficiency	56	62	64	69	71	72	73	73
	O.T.	41,220	41,630	39,675	34,105	31,610	29,470	25,860	20,705
70	Me.HP	1.67	3.05	4.22	6.51	7.28	8.09	9.25	11.27
	Th.HP	1.10	2.03	2.81	4.31	4.79	5.00	5.43	5.56
	Th.HP Fan	1.67	3.05	4.22	6.51	7.28	8.09	9.25	11.13
	Efficiency	55	61	63	68	70	71	72	72
	O.T.	40,535	41,010	39,110	33,655	31,205	29,100	25,540	20,450

Key: Me.HP = Mech. Input Power (HP) Th.HP = Thermal Input Power - No Fan
 O.T. = Output Torque (In. Lb.) Th.HP Fan = Thermal Input Power - Fan





DIMENSIONS Size 70 heavyDRIVE "HvD" Series

BORE INCHES	GEARSHAFT NUMBER	KEYWAY SIZE
4.4375*	80-S60-407	1 X 1/2
3.9375*	80-S60-315	1 X 1/2

Solid Shaft

Model HvD070 – Worm Over Gear net wt. 535 lbs

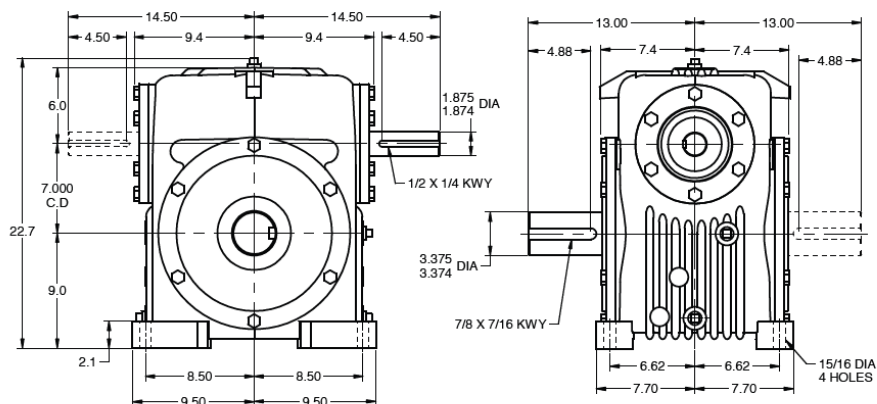

Hollow Shaft

net wt. 560 lbs

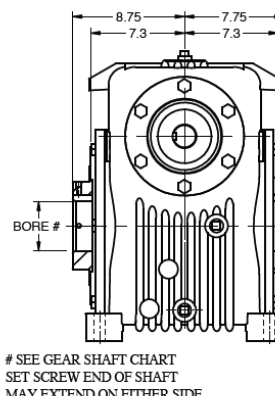

Model HvD070 – Worm Under Gear net wt. 605 lbs

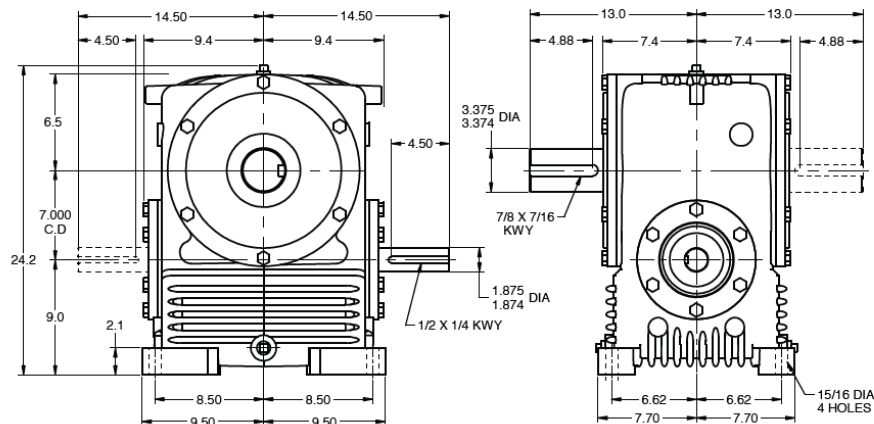

net wt. 630 lbs

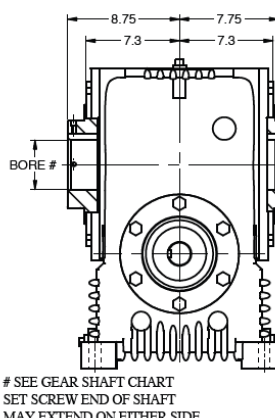

Model HvD070 – Vertical Gear Shaft

net wt. 600 lbs

net wt. 625 lbs

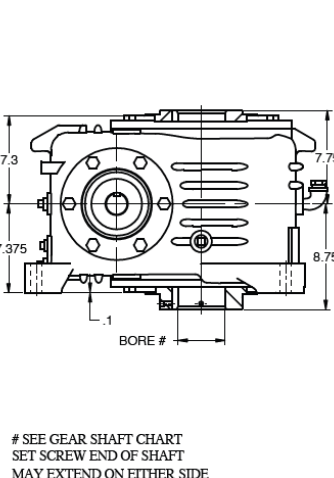
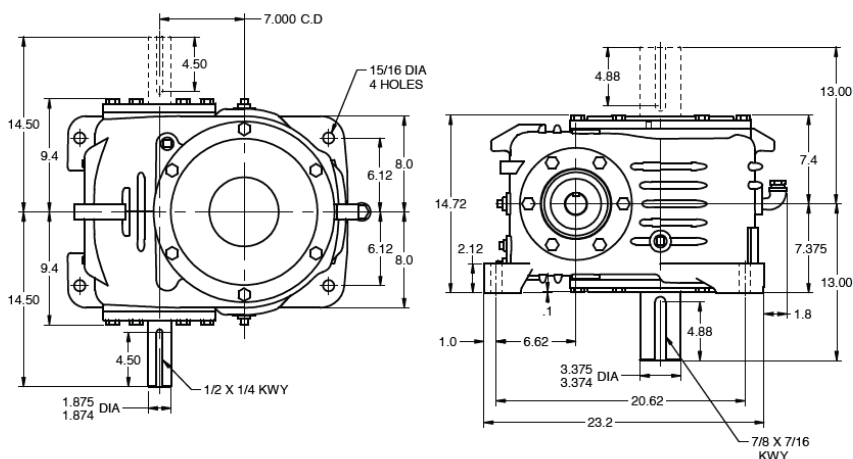

INPUT AND OUTPUT SHAFT MAY EXTEND ON EITHER SIDE OR MAY BE DOUBLE EXTENDED

SEE GEAR SHAFT CHART SET SCREW END OF SHAFT MAY EXTEND ON EITHER SIDE



RATINGS Size 70 heavyDRIVE “HvD” Series

Servo Worm Gearboxes Ultra Quiet Cast Iron Housing



AGMA HORSEPOWER & OUTPUT TORQUE RATINGS FOR 1.0 SERVICE FACTOR									
		Worm RPM							
Ratio to 1		100	200	300	580	720	870	1150	1750
5	Me.HP	20.90	37.29	49.72	72.10	80.50	88.26	100.23	115.65
	Th.HP	8.49	12.85	16.54	23.55	26.36	28.43	30.71	33.78
	Th.HP Fan	16.97	25.69	33.07	47.11	52.73	56.86	61.42	67.56
	Efficiency	92	93	94	94	94	95	95	95
	O.T.	60,560	54,625	49,080	36,810	33,110	30,360	26,085	19,780
10	Me.HP	14.56	26.41	36.12	53.50	60.30	66.52	76.21	88.78
	Th.HP	7.56	10.86	13.94	19.11	20.93	22.34	24.01	25.62
	Th.HP Fan	14.56	21.71	27.88	38.23	41.86	44.67	48.01	51.24
	Efficiency	86	88	89	90	90	92	93	93
	O.T.	78,910	73,210	67,510	52,305	47,485	44,320	38,830	29,725
15	Me.HP	11.80	21.44	29.41	43.92	49.45	54.64	62.55	73.96
	Th.HP	7.87	9.46	11.70	15.82	16.95	17.93	18.95	20.24
	Th.HP Fan	11.80	18.92	23.40	31.64	33.89	35.85	37.91	40.48
	Efficiency	82	84	85	88	89	90	91	91
	O.T.	91,425	85,110	78,740	62,970	57,760	53,415	46,775	36,345
20	Me.HP	9.03	16.42	22.57	33.75	38.02	41.77	47.99	56.80
	Th.HP	5.17	8.39	10.34	14.04	14.87	15.61	16.23	16.94
	Th.HP Fan	9.03	16.42	20.68	28.08	29.73	31.22	32.47	33.88
	Efficiency	78	80	81	86	86	86	87	88
	O.T.	88,795	82,780	76,790	63,055	57,220	52,030	45,750	35,995
25	Me.HP	7.28	13.25	18.18	27.32	30.71	33.85	38.93	45.96
	Th.HP	4.16	7.13	8.91	12.19	12.71	13.13	13.51	14.04
	Th.HP Fan	7.28	13.25	17.82	24.38	25.42	26.26	27.03	28.08
	Efficiency	74	78	80	84	84	86	87	87
	O.T.	84,815	81,405	76,360	62,325	56,425	52,710	46,390	35,990
30	Me.HP	6.10	11.10	15.26	22.89	25.73	28.36	32.62	38.68
	Th.HP	4.06	5.94	7.72	10.50	11.07	11.50	11.79	12.14
	Th.HP Fan	6.10	11.10	15.26	21.00	22.14	23.00	23.59	24.29
	Efficiency	71	73	75	78	81	82	83	83
	O.T.	81,815	76,600	72,115	58,185	54,705	50,530	44,495	34,680
40	Me.HP	4.58	8.36	11.48	17.21	19.35	21.33	24.62	29.09
	Th.HP	2.61	4.78	6.42	11.38	9.43	9.88	10.24	10.59
	Th.HP Fan	4.58	8.36	11.48	17.21	18.87	19.77	20.47	21.18
	Efficiency	64	66	70	75	76	78	79	79
	O.T.	73,945	69,565	67,485	56,095	51,465	48,195	42,615	33,095
50	Me.HP	3.68	6.71	9.21	13.84	15.52	17.11	19.75	23.34
	Th.HP	2.09	3.83	5.26	7.39	7.82	8.22	8.79	9.41
	Th.HP Fan	3.68	6.71	9.21	13.84	15.52	16.45	17.58	18.82
	Efficiency	57	63	67	73	74	75	76	76
	O.T.	66,035	66,580	64,770	54,885	50,245	46,465	41,110	31,925
60	Me.HP	3.07	5.60	7.68	11.55	12.95	14.28	16.48	19.56
	Th.HP	1.75	3.18	4.45	6.52	6.89	7.29	7.96	8.47
	Th.HP Fan	3.07	5.60	7.68	11.55	12.95	14.28	15.91	16.94
	Efficiency	56	62	64	69	71	72	73	73
	O.T.	64,960	65,610	61,950	51,950	48,275	44,665	39,540	30,845
70	Me.HP	2.63	4.81	6.59	9.91	11.11	12.25	14.14	16.79
	Th.HP	1.49	2.74	3.79	5.82	6.47	6.76	7.34	7.52
	Th.HP Fan	2.63	4.81	6.59	9.91	11.11	12.25	14.14	15.04
	Efficiency	55	61	63	68	70	71	72	72
	O.T.	63,885	64,640	61,065	51,265	47,655	44,105	39,050	30,465

Key: Me.HP = Mech. Input Power (HP) Th.HP = Thermal Input Power - No Fan
 O.T. = Output Torque (In. Lb.) Th.HP Fan = Thermal Input Power - Fan





DIMENSIONS Size 80 heavyDRIVE "HvD" Series

BORE INCHES	GEARSHAFT NUMBER	KEYWAY SIZE
4.4375*	80-S60-407	1 X 1/2
3.9375*	80-S60-315	1 X 1/2

Solid Shaft

Model HvD080 – Worm Over Gear net wt. 690 lbs

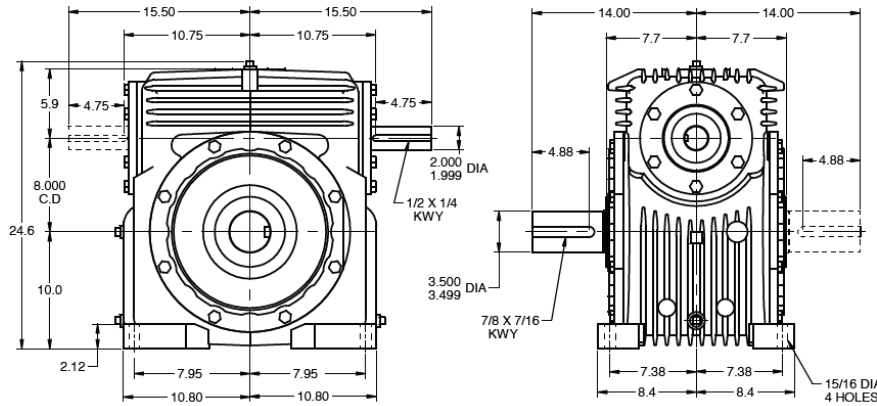

Hollow Shaft

net wt. 720 lbs

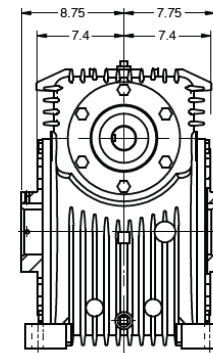

SEE GEAR SHAFT CHART SET SCREW END OF SHAFT MAY EXTEND ON EITHER SIDE

Model HvD080 – Worm Under Gear net wt. 880 lbs

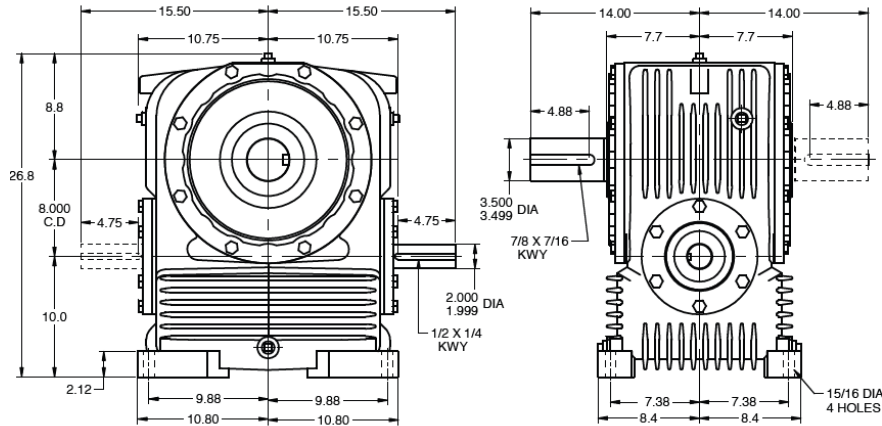

net wt. 910 lbs

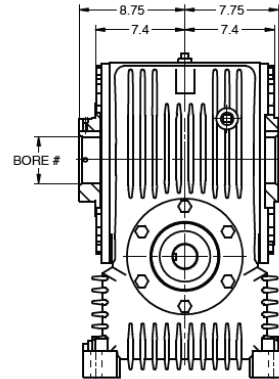

SEE GEAR SHAFT CHART SET SCREW END OF SHAFT MAY EXTEND ON EITHER SIDE

Model HvD080 – Vertical Gear Shaft

net wt. 725 lbs

net wt. 755 lbs

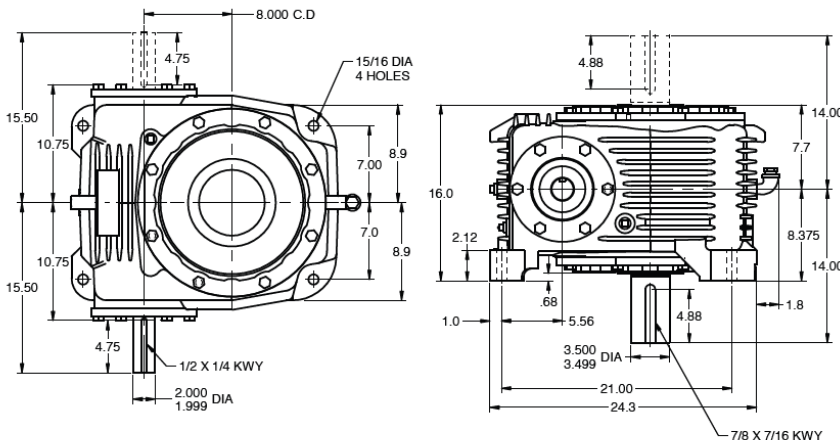

SEE GEAR SHAFT CHART SET SCREW END OF SHAFT MAY EXTEND ON EITHER SIDE

INPUT AND OUTPUT SHAFT MAY EXTEND ON EITHER SIDE OR MAY BE DOUBLE EXTENDED



RATINGS Size 80 heavyDRIVE "HvD" Series

Servo Worm Gearboxes Ultra Quiet Cast Iron Housing



AGMA HORSEPOWER & OUTPUT TORQUE RATINGS FOR 1.0 SERVICE FACTOR									
		Worm RPM							
Ratio to 1		100	200	300	580	720	870	1150	1750
5	Me.HP	31.03	54.63	71.62	102.29	114.21	124.91	139.75	161.85
	Th.HP	12.90	19.52	25.13	35.79	40.06	43.20	46.67	51.33
	Th.HP Fan	25.79	39.04	50.25	71.59	80.12	86.40	93.33	102.67
	Efficiency	92	93	94	94	94	95	95	95
	O.T.	89,915	80,025	70,695	52,225	46,970	42,965	36,370	27,680
10	Me.HP	21.74	39.24	53.17	77.78	87.61	96.01	110.52	128.53
	Th.HP	11.48	16.50	21.18	29.05	31.81	33.94	36.48	38.93
	Th.HP Fan	21.74	33.00	42.36	58.09	63.61	67.88	72.96	77.87
	Efficiency	86	88	89	90	90	92	93	93
	O.T.	117,795	108,785	99,370	76,040	68,995	63,960	56,310	43,035
15	Me.HP	17.64	31.93	43.47	64.06	72.10	79.69	91.11	105.66
	Th.HP	11.76	14.37	17.78	24.04	25.75	27.24	28.80	30.76
	Th.HP Fan	17.64	28.74	35.56	48.07	51.50	54.48	57.60	61.51
	Efficiency	82	84	85	88	89	90	91	91
	O.T.	136,710	126,715	116,395	91,850	84,225	77,905	68,135	51,925
20	Me.HP	13.49	24.45	33.37	49.37	55.45	61.32	69.91	81.57
	Th.HP	7.85	12.75	15.71	21.33	22.59	23.72	24.67	25.74
	Th.HP Fan	13.49	24.45	31.42	42.67	45.18	47.44	49.33	51.48
	Efficiency	78	80	81	86	86	86	87	88
	O.T.	132,560	123,245	113,525	92,230	83,445	76,370	66,645	51,685
25	Me.HP	10.88	19.70	26.93	39.97	44.92	49.38	56.73	66.01
	Th.HP	6.33	10.84	13.54	18.53	19.31	19.95	20.53	21.33
	Th.HP Fan	10.88	19.70	26.93	37.05	38.62	39.91	41.07	42.67
	Efficiency	74	78	80	84	84	86	87	87
	O.T.	126,825	120,980	113,115	91,175	82,540	76,890	67,595	51,690
30	Me.HP	9.12	16.53	22.61	33.49	37.74	41.64	47.70	55.57
	Th.HP	6.08	9.03	11.73	15.96	16.82	17.47	17.92	18.45
	Th.HP Fan	9.12	16.53	22.61	31.91	33.65	34.95	35.84	36.91
	Efficiency	71	73	75	78	81	82	83	83
	O.T.	122,340	114,045	106,830	85,120	80,255	74,180	65,075	49,820
40	Me.HP	6.86	12.43	17.00	25.25	28.38	31.31	35.87	41.99
	Th.HP	3.97	7.26	9.76	16.83	14.34	15.02	15.56	16.09
	Th.HP Fan	6.86	12.43	17.00	25.25	28.38	30.04	31.11	32.18
	Efficiency	64	66	70	75	76	78	79	79
	O.T.	110,575	103,385	99,975	82,285	75,500	70,750	62,105	47,775
50	Me.HP	5.50	9.97	13.64	20.25	22.77	25.12	28.78	33.68
	Th.HP	3.18	5.81	8.00	11.24	11.89	12.50	13.35	14.30
	Th.HP Fan	5.50	9.97	13.64	20.25	22.77	24.99	26.71	28.60
	Efficiency	57	63	67	73	74	75	76	76
	O.T.	98,745	98,950	95,950	80,305	73,710	68,210	59,905	46,080
60	Me.HP	4.59	8.32	11.38	16.90	19.00	20.96	24.01	28.11
	Th.HP	2.66	4.84	6.76	9.91	10.47	11.08	12.09	12.87
	Th.HP Fan	4.59	8.32	11.38	16.90	19.00	20.96	24.01	25.74
	Efficiency	56	62	64	69	71	72	73	73
	O.T.	97,140	97,510	91,775	76,005	70,820	65,570	57,615	44,320
70	Me.HP	3.94	7.14	9.77	14.51	16.31	17.99	20.61	24.12
	Th.HP	2.27	4.17	5.76	8.84	9.83	10.27	11.15	11.42
	Th.HP Fan	3.94	7.14	9.77	14.51	16.31	17.99	20.61	22.85
	Efficiency	55	61	63	68	70	71	72	72
	O.T.	95,535	96,065	90,460	75,000	69,915	64,745	56,905	43,775





DIMENSIONS Size 100 heavyDRIVE "HvD" Series

BORE INCHES	GEARSHAFT NUMBER	KEYWAY SIZE
5.9375	100-S61-515	1 1/4 X 7/16

Solid Shaft

Model HvD100 – Worm Over Gear net wt. 1360 lbs.

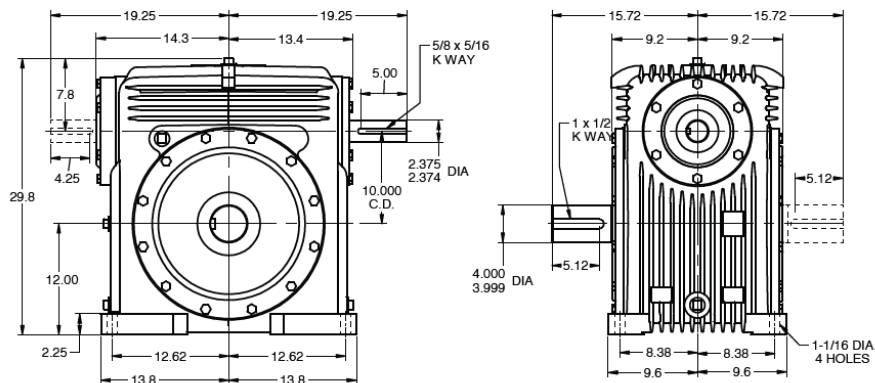

Hollow Shaft

net wt. 1435 lbs.

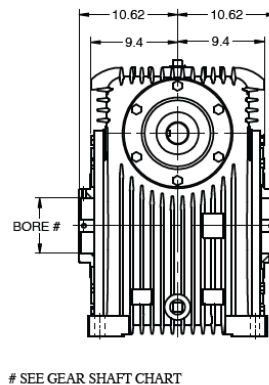

Model HvD100 – Worm Under Gear net wt. 1680 lbs.

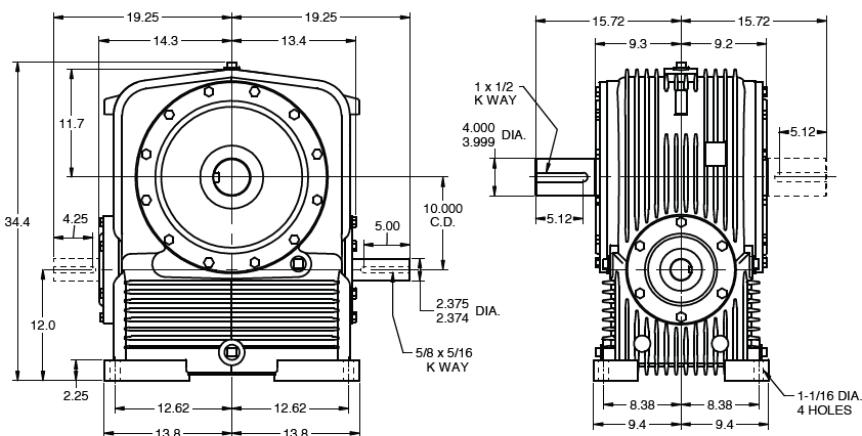

net wt. 1755 lbs.

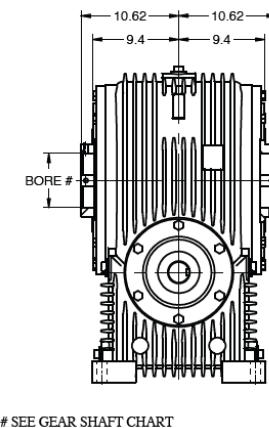

Model HvD100 – Vertical Gear Shaft

net wt. 1550 lbs.

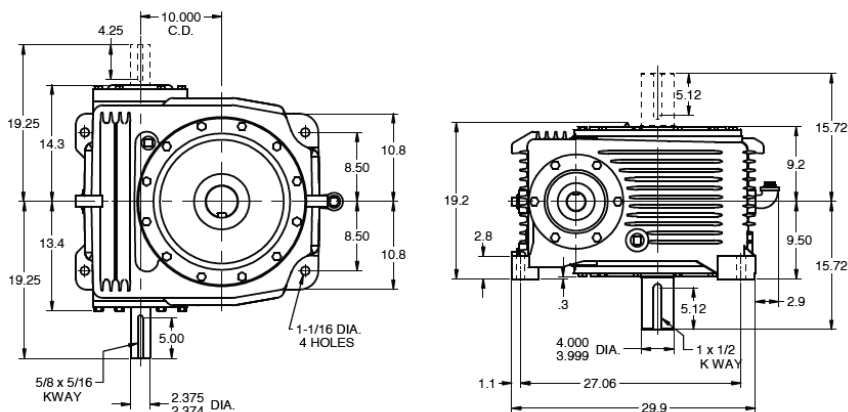

net wt. 1625 lbs.

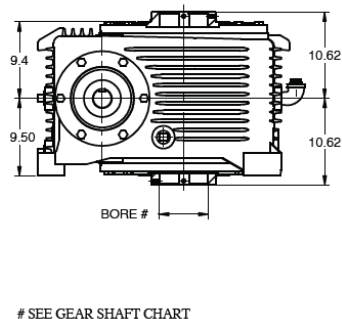

RATINGS Size 100 heavyDRIVE “HvD” Series

Servo Worm Gearboxes Ultra Quiet Cast Iron Housing



AGMA HORSEPOWER & OUTPUT TORQUE RATINGS FOR 1.0 SERVICE FACTOR									
Ratio to 1		Worm RPM							
		100	200	300	580	720	870	1150	1750
5	Me.HP	58.05	98.65	125.54	177.07	196.63	213.20	231.67	272.58
	Th.HP	23.59	36.51	48.34	68.86	77.07	86.19	93.10	102.42
	Th.HP Fan	47.17	73.02	96.68	137.72	154.14	172.38	186.21	204.83
	Efficiency	94	95	96	96	97	97	97	97
	O.T.	171,875	147,605	126,550	92,320	83,450	74,880	61,555	47,595
10	Me.HP	40.93	72.26	95.47	136.70	152.42	166.98	188.26	216.10
	Th.HP	19.47	28.48	36.98	51.36	58.17	62.07	68.23	72.82
	Th.HP Fan	38.94	56.97	73.95	102.73	116.34	124.14	136.46	145.64
	Efficiency	88	90	91	92	94	94	95	95
	O.T.	226,900	204,850	182,450	136,605	125,365	113,665	97,980	73,910
15	Me.HP	33.10	58.81	77.98	112.16	125.72	137.56	155.67	179.16
	Th.HP	16.13	24.04	29.93	41.50	44.96	48.17	51.71	55.22
	Th.HP Fan	32.26	48.07	59.85	83.00	89.91	96.35	103.43	110.45
	Efficiency	84	86	87	90	92	92	93	93
	O.T.	262,765	238,975	213,695	164,470	151,805	137,465	118,965	89,975
20	Me.HP	25.35	45.14	60.01	86.25	96.74	106.30	119.51	138.49
	Th.HP	12.77	20.90	25.86	36.18	38.31	40.22	42.18	44.44
	Th.HP Fan	25.35	41.80	51.71	72.36	76.61	80.44	84.36	88.89
	Efficiency	80	82	83	88	88	88	89	90
	O.T.	255,535	233,170	209,185	164,895	148,985	135,485	116,545	89,745
25	Me.HP	20.45	36.42	48.44	69.88	77.92	85.62	97.06	111.55
	Th.HP	10.17	17.63	22.19	30.98	32.30	33.84	35.11	36.48
	Th.HP Fan	20.34	35.25	44.39	61.97	64.59	67.67	70.23	72.96
	Efficiency	76	80	82	86	88	88	89	89
	O.T.	244,825	229,470	208,520	163,190	149,995	136,400	118,315	89,350
30	Me.HP	17.14	30.52	40.58	58.54	65.28	71.73	81.32	93.46
	Th.HP	11.12	14.48	18.91	25.95	27.69	28.90	29.79	30.68
	Th.HP Fan	17.14	28.96	37.81	51.91	55.38	57.79	59.59	61.36
	Efficiency	73	75	77	80	84	84	85	85
	O.T.	236,430	216,285	196,860	152,620	143,950	130,905	113,605	85,795
40	Me.HP	12.89	22.95	30.52	44.03	49.09	53.94	61.16	70.28
	Th.HP	6.25	11.49	15.55	28.98	23.32	24.43	25.39	26.26
	Th.HP Fan	12.51	22.95	30.52	44.03	46.63	48.85	50.78	52.53
	Efficiency	66	68	72	77	80	80	81	81
	O.T.	214,330	196,625	184,570	147,290	137,460	125,005	108,550	81,975
50	Me.HP	10.34	18.44	24.59	35.52	39.63	43.42	49.46	56.68
	Th.HP	4.97	9.16	12.67	18.01	19.15	20.14	21.58	23.11
	Th.HP Fan	9.94	18.31	24.59	35.52	38.31	40.27	43.16	46.22
	Efficiency	59	65	69	75	77	77	78	78
	O.T.	192,110	188,815	178,120	144,685	133,520	121,070	105,680	79,585
60	Me.HP	8.63	15.39	20.51	29.64	33.07	36.24	41.27	47.30
	Th.HP	4.15	7.61	10.65	15.76	16.71	17.72	19.38	20.64
	Th.HP Fan	8.30	15.22	20.51	29.64	33.07	35.44	38.76	41.27
	Efficiency	58	64	66	71	74	74	75	75
	O.T.	189,105	186,160	170,605	137,150	128,485	116,505	101,750	76,630
70	Me.HP	7.40	13.21	17.61	25.44	28.39	31.10	35.42	40.60
	Th.HP	3.54	6.54	9.07	14.03	15.65	16.39	17.83	18.27
	Th.HP Fan	7.08	13.09	17.61	25.44	28.39	31.10	35.42	36.54
	Efficiency	57	63	65	70	73	73	74	74
	O.T.	186,095	183,495	168,245	135,400	126,920	115,085	100,530	75,705





DIMENSIONS Size 120 heavyDRIVE "HvD" Series

BORE INCHES	GEARSHAFT NUMBER	KEYWAY SIZE
7.9375	120-S61-715	1 1/2 X 1/2

Solid Shaft

Model HvD120 – Worm Over Gear net wt. 2635 lbs.

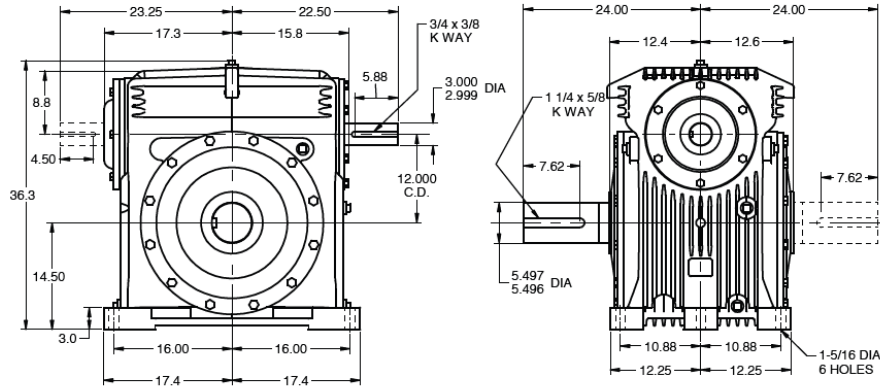

Hollow Shaft

net wt. 2635 lbs.

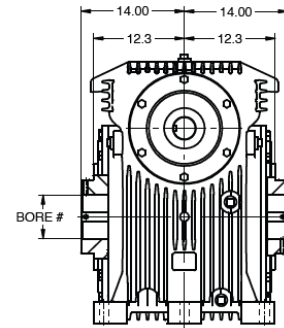

SEE GEAR SHAFT CHART

Model HvD120 – Worm Under Gear net wt. 2775 lbs.

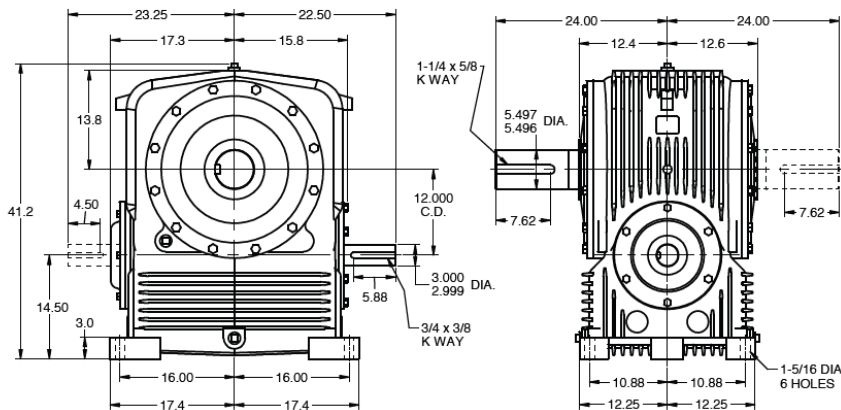

net wt. 2775 lbs.

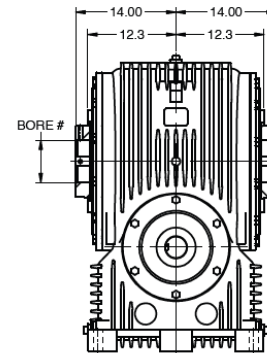

SEE GEAR SHAFT CHART

Model HvD120 – Vertical Gear Shaft

net wt. 2995 lbs.

net wt. 2995 lbs.

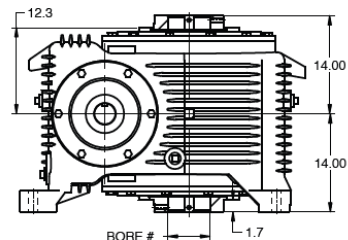
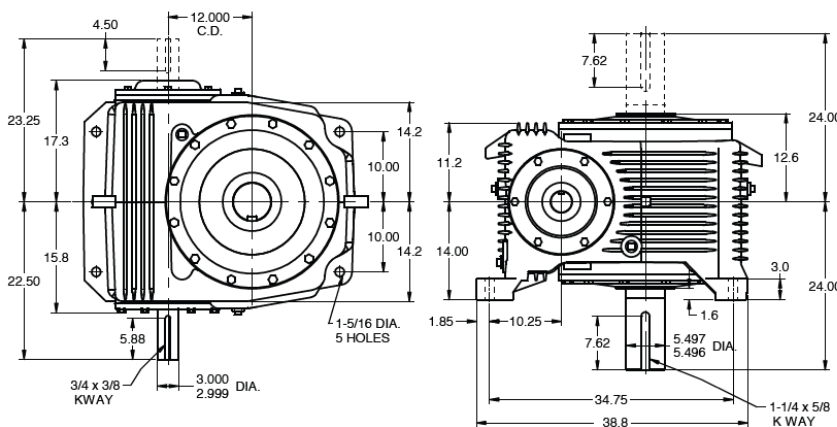

SEE GEAR SHAFT CHART

INPUT AND OUTPUT SHAFT MAY EXTEND ON EITHER SIDE OR MAY BE DOUBLE EXTENDED



RATINGS Size 120 heavyDRIVE “HvD” Series

Servo Worm Gearboxes Ultra Quiet Cast Iron Housing



AGMA HORSEPOWER & OUTPUT TORQUE RATINGS FOR 1.0 SERVICE FACTOR								
		Worm RPM						
Ratio to 1		100	200	300	580	720	870	1150
5	Me.HP	97.66	160.36	199.46	279.03	307.46	322.92	360.54
	Th.HP	32.97	51.04	67.58	96.27	107.74	120.49	130.16
	Th.HP Fan	65.95	102.09	135.16	192.54	215.49	240.99	260.33
	Efficiency	94	95	96	96	97	97	97
	O.T.	289,165	239,940	201,055	145,480	130,480	113,415	95,795
10	Me.HP	69.42	119.50	153.17	218.02	240.67	263.11	287.25
	Th.HP	27.22	39.82	51.69	71.81	81.32	86.78	95.39
	Th.HP Fan	54.45	79.64	103.39	143.62	162.64	173.55	190.78
	Efficiency	88	90	91	92	94	94	95
	O.T.	384,890	338,790	292,715	217,870	197,955	179,100	149,495
15	Me.HP	56.15	97.31	125.83	179.16	198.25	217.23	237.20
	Th.HP	22.55	33.60	41.84	58.02	62.85	67.35	72.30
	Th.HP Fan	45.10	67.20	83.68	116.03	125.70	134.69	144.59
	Efficiency	84	86	87	90	92	92	93
	O.T.	445,755	395,415	344,835	262,720	239,385	217,080	181,275
20	Me.HP	43.08	74.85	96.65	137.85	152.65	167.39	183.95
	Th.HP	17.85	29.22	36.15	50.58	53.55	56.23	58.97
	Th.HP Fan	35.70	58.44	72.30	101.16	107.11	112.46	117.94
	Efficiency	80	82	83	88	88	88	89
	O.T.	434,270	386,660	336,930	263,530	235,085	213,335	179,375
25	Me.HP	34.70	60.41	78.21	111.03	123.39	135.35	148.86
	Th.HP	14.21	24.64	31.03	43.31	45.15	47.31	49.09
	Th.HP Fan	28.43	49.28	62.05	86.63	90.30	94.61	98.18
	Efficiency	76	80	82	86	88	88	89
	O.T.	415,355	380,555	336,700	259,285	237,520	215,625	181,445
30	Me.HP	29.07	50.61	65.68	93.02	103.38	113.40	125.30
	Th.HP	15.55	20.24	26.43	36.28	38.71	40.40	41.65
	Th.HP Fan	29.07	40.48	52.87	72.57	77.43	80.80	83.30
	Efficiency	73	75	77	80	84	84	85
	O.T.	401,110	358,695	318,615	242,500	227,950	206,930	175,040
40	Me.HP	21.90	38.06	49.39	70.40	78.29	85.61	94.23
	Th.HP	8.74	16.07	21.74	40.52	32.60	34.15	35.50
	Th.HP Fan	17.49	32.13	43.48	70.40	65.19	68.30	71.00
	Efficiency	66	68	72	77	80	80	81
	O.T.	364,260	326,090	298,725	235,515	219,220	198,380	167,250
50	Me.HP	17.57	30.59	39.71	56.47	62.80	68.67	75.58
	Th.HP	6.95	12.80	17.72	25.18	26.78	28.15	30.17
	Th.HP Fan	13.90	25.60	35.44	50.37	53.55	56.30	60.34
	Efficiency	59	65	69	75	77	77	78
	O.T.	326,495	313,165	287,710	230,010	211,565	191,450	161,490
60	Me.HP	14.66	25.53	33.14	47.12	52.40	57.30	63.07
	Th.HP	5.80	10.64	14.90	22.03	23.36	24.78	27.10
	Th.HP Fan	11.60	21.28	29.79	44.07	46.71	49.55	54.19
	Efficiency	58	64	66	71	74	74	75
	O.T.	321,390	308,755	275,570	218,035	203,590	184,235	155,485
70	Me.HP	12.58	21.91	28.44	40.44	44.98	49.18	54.13
	Th.HP	4.95	9.15	12.68	19.61	21.88	22.91	24.93
	Th.HP Fan	9.90	18.30	25.37	39.22	43.76	45.82	49.86
	Efficiency	57	63	65	70	73	73	74
	O.T.	316,270	304,340	271,755	215,250	201,110	181,990	153,615



NEMA Worm* Gearboxes Ultra Quiet Aluminum Housing

Aluminum Housing CvK Gearing

With capabilities up to 20HP and output torque up to 8,000 lb. in. Series CvK can provide design flexibility with lasting performance.

AN ECONOMIC SOLUTION THAT PACKS A PUNCH. Fangtooth Series CvK gearboxes provide an economical, flexible, and compact solution to fulfill the low-to-medium power range requirements.

Easy motor removal with fret-free motor bushing

Interchanges with most competitors like

Boston Gear	Tigear
Grove	Omnibox
Raider	Ohio
Cobra	

*CvK Gearing has higher torque density than traditional worm gears and performs in a similar manner.

Conveyor Killer “CvK” Series



Sizes
CvK002NW
CvK003NW
CvK004NW
CvK005NW
CvK006NW
CvK008NW
CvK009NW
CvK011NW

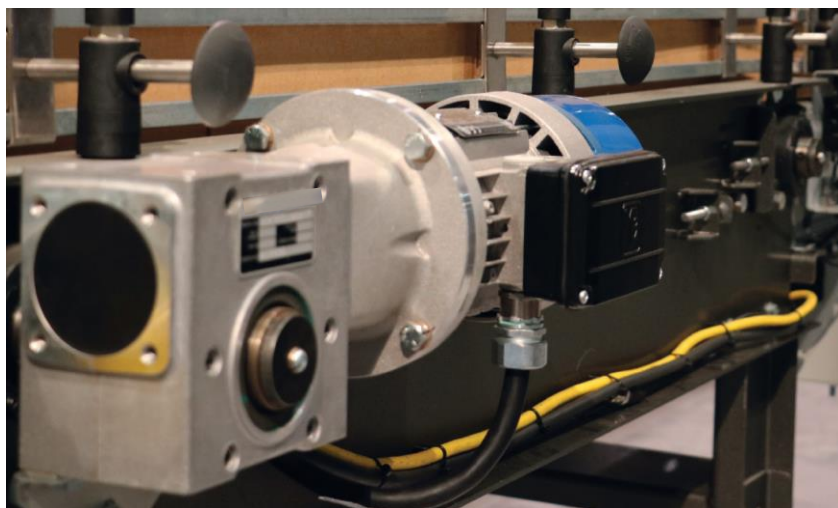

Fangtooth Conveyor Killer CvK
Ultra Quiet Aluminum
Gearbox Technical Information

www.fangtooth-linear.com

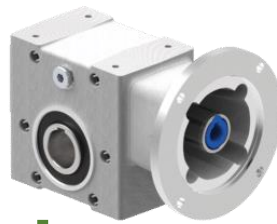

ORDERING CODE

Conveyor Killer “CvK” Series

NEMA Worm* Gearboxes
Ultra Quiet Aluminum Housing

Model: CvK008NW-S010W-031HHK/NEMA54

Gearbox Series
CvK – Conveyor Killer

Gearbox Size
002 – 1.33 inch CD
003 – 1.54 inch CD
004 – 1.75 inch CD
005 – 1.97 inch CD
006 – 2.38 inch CD
008 – 2.62 inch CD
009 – 3.00 inch CD
010 – 3.25 inch CD
011 – 3.54 inch CD

Gearbox Drive Type
NW – NEMA Worm

Gearbox Backlash
S – Standard

Gearbox Ratio

005 – 5:1	015 – 15:1	030 – 30:1	060 – 60:1
007 – 7.5:1	020 – 20:1	040 – 40:1	
010 – 10:1	025 – 25:1	050 – 50:1	

Gearbox Mounting

W – Standard

B – Horizontal Base

(Low Worm Under)
L – Vertical Base

(High Worm Over)
H – High Vertical

K – Output Bracket

T – Torque Arm Mount

Gearbox Input
SIP – Single Input
DIP – Dual Input
Motor Model – Mounting Kit

Gearbox Output Type
K – Keyed

Gearbox Output Location
HH – Hollow Bore Through
ZZ – Solid Shaft, Double Ext
Z1 – Solid Shaft “1” side
Z2 – Solid Shaft “2” side

Gearbox Output Size
– size in 16th of an inch
##M – size in mm



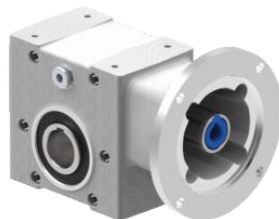

RATINGS

Conveyor Killer "CvK" Series

NEMA Worm* Gearboxes Ultra Quiet Aluminum Housing

RATIO:1	OUTPUT SPEED RPM	CAPACITY	SIZE OF UNIT								
			02	03	04	05	06	08	09	10	11
5	350	Input Power, HP (mech)	1.76	2.51	3.45	4.62	7.47	9.62	13.6	16.6	20.6
		Input Power, HP (therm)	1.76	2.51	3.45	4.62	7.47	9.62	12.7	16.4	17.6
		Output Torque, lb-in (mech)	275	401	559	757	1240	1610	2280	2800	3500
		Efficiency, %	87	89	90	91	92	93	93	94	94
7.5	233	Input Power, HP (mech)	1.30	1.85	2.54	3.39	5.45	6.97	9.76	11.9	14.7
		Input Power, HP (therm)	1.30	1.85	2.54	3.39	5.45	6.97	9.76	11.9	14.2
		Output Torque, lb-in (mech)	296	433	603	818	1340	1720	2430	2970	3700
		Efficiency, %	84	86	88	89	91	92	92	93	93
10	175	Input Power, HP (mech)	1.05	1.47	1.84	2.63	4.17	4.98	6.99	8.93	11.0
		Input Power, HP (therm)	1.05	1.47	1.84	2.63	4.17	4.98	6.99	8.93	11.0
		Output Torque, lb-in (mech)	308	446	570	830	1340	1620	2290	2950	3660
		Efficiency, %	82	84	86	88	89	90	91	92	92
15	117	Input Power, HP (mech)	0.79	1.11	1.51	2.02	3.26	4.13	5.79	7.18	8.93
		Input Power, HP (therm)	0.79	1.11	1.51	2.02	3.26	4.13	5.79	7.18	8.93
		Output Torque, lb-in (mech)	325	479	674	919	1520	1950	2770	3460	4330
		Efficiency, %	76	80	82	84	87	88	89	89	90
20	88	Input Power, HP (mech)	0.62	0.88	1.20	1.60	2.59	3.34	4.70	5.74	7.15
		Input Power, HP (therm)	0.62	0.88	1.20	1.60	2.59	3.34	4.70	5.74	7.00
		Output Torque, lb-in (mech)	319	476	675	927	1550	2030	2900	3570	4480
		Efficiency, %	71	75	78	80	83	84	86	86	87
25	70	Input Power, HP (mech)	0.56	0.79	1.08	1.44	2.32	2.72	3.81	4.65	5.76
		Input Power, HP (therm)	0.56	0.79	1.08	1.44	2.32	2.72	3.81	4.65	5.71
		Output Torque, lb-in (mech)	340	510	726	1000	1680	1990	2840	3490	4370
		Efficiency, %	67	72	75	77	80	81	83	83	84
30	58	Input Power, HP (mech)	0.49	0.67	0.90	1.20	1.91	2.45	3.43	4.18	5.20
		Input Power, HP (therm)	0.49	0.67	0.90	1.20	1.91	2.45	3.43	4.18	5.20
		Output Torque, lb-in (mech)	332	494	700	961	1610	2100	3010	3700	4640
		Efficiency, %	63	68	72	74	78	79	81	82	83
40	44	Input Power, HP (mech)	0.38	0.51	0.68	0.89	1.41	1.79	2.49	3.03	3.75
		Input Power, HP (therm)	0.38	0.51	0.68	0.89	1.41	1.79	2.49	3.03	3.75
		Output Torque, lb-in (mech)	298	444	630	866	1450	1890	2710	3340	4180
		Efficiency, %	55	60	64	67	72	73	75	76	77
50	35	Input Power, HP (mech)	0.33	0.44	0.58	0.75	1.16	1.46	2.01	2.43	2.99
		Input Power, HP (therm)	0.33	0.44	0.58	0.75	1.16	1.46	2.01	2.43	2.99
		Output Torque, lb-in (mech)	291	434	610	832	1380	1790	2550	3140	3920
		Efficiency, %	49	54	58	62	66	68	70	72	73
60	29	Input Power, HP (mech)	0.29	0.38	0.50	0.64	0.98	1.24	1.70	2.05	2.52
		Input Power, HP (therm)	0.29	0.38	0.50	0.64	0.98	1.24	1.70	2.05	2.52
		Output Torque, lb-in (mech)	272	404	570	782	1300	1700	2430	2990	3740
		Efficiency, %	43	49	53	57	61	64	66	67	69

NOTE: Thermal rating for units driven by fan cooled motor
Ratings assumes units are fitted with standard output shafts





O/P SHAFT OPTIONS Conveyor Killer “CvK” Series

NEMA Worm* Gearboxes
Ultra Quiet Aluminum Housing

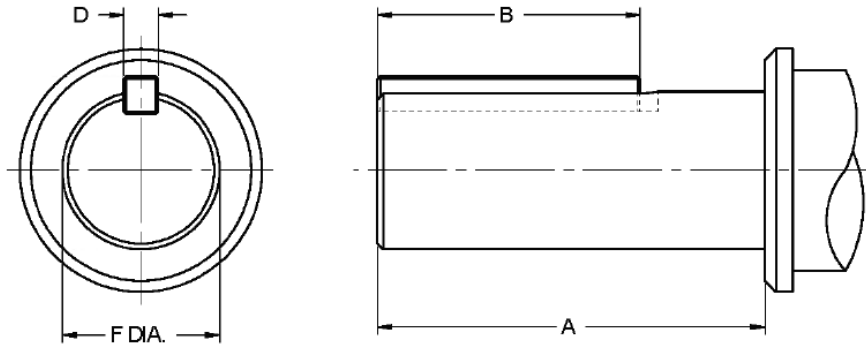

Unit Size	Type of Output Shaft	Column 11 Entry		A	B	D (Key)	F Dia.
		Single Extended	Double Extended				
02	Standard Inch (in)	N	P	1.88	1.00	3/16 X 3/16	0.7495 ± 0.0005
	Reduced Dia. (in)	Q	R	1.88	1.00	3/16 X 3/16	0.6245 ± 0.0005
03	Standard Inch (in)	N	P	1.99	1.13	3/16 X 3/16	0.7495 ± 0.0005
04	Standard Inch (in)	N	P	1.97	1.25	1/4 X 1/4	0.9995 ± 0.0005
	Reduced Dia. (in)	Q	R	1.97	1.25	3/16 X 3/16	0.8745 ± 0.0005
05	Standard Inch (in)	N	P	2.39	1.50	1/4 X 1/4	1.1245 ± 0.0005
	Reduced Dia. (in)	Q	R	2.39	1.50	1/4 X 1/4	0.9995 ± 0.0005
06	Standard Inch (in)	N	P	2.77	1.88	1/4 X 1/4	1.1245 ± 0.0005
08	Standard Inch (in)	N	P	2.68	1.94	3/8 X 3/8	1.4995 ± 0.0005
	Reduced Dia. (in)	Q	R	2.68	1.94	1/4 X 1/4	1.1245 ± 0.0005
09	Standard Inch (in)	N	P	3.80	2.00	3/8 X 3/8	1.4995 ± 0.0005
	Reduced Dia. (in)	Q	R	3.80	2.00	1/4 X 1/4	1.2495 ± 0.0005
10	Standard Inch (in)	N	P	3.83	2.25	3/8 X 3/8	1.4995 ± 0.0005
	Reduced Dia. (in)	Q	R	3.83	2.25	5/16 X 5/16	1.3745 ± 0.0005
11	Standard Inch (in)	N	P	4.15	2.63	1/2 X 1/2	1.8745 ± 0.0005
	Reduced Dia. (in)	Q	R	4.15	2.63	3/8 X 3/8	1.6245 ± 0.0005





O/P BORE OPTIONS Conveyor Killer “CvK” Series

**NEMA Worm* Gearboxes
Ultra Quiet Aluminum Housing**

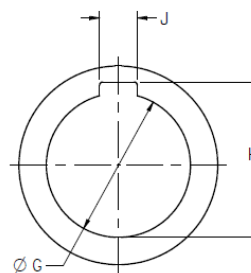
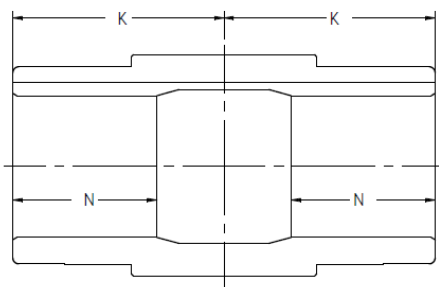

Output Bore

Standard Bore Sizes

Unit Size	Column T1 Entry	Ø G	J	H	K	N
Standard Inch (in)						
02	A	1.0005 ± 0.0005	0.251	1.089	1.93	1.1
03	A	1.0005 ± 0.0005	0.251	1.089	2.12	1.1
04	A	1.4380 ± 0.0005	0.376	1.550	2.15	1.4
05	A	1.4380 ± 0.0005	0.376	1.550	2.11	1.4
06	A	1.4385 ± 0.0005	0.376	1.550	2.13	1.4
08	A	1.9380 ± 0.0005	0.501	2.104	2.72	1.9
09	A	2.1880 ± 0.0005	0.501	2.359	2.72	2.2
10	A	2.1880 ± 0.0005	0.501	2.359	2.99	2.2
11	A	2.9380 ± 0.0005	0.751	3.151	3.33	2.9
Standard Metric (mm)						
02	M	20 + 0.021	6	22.84	49.0	29.0
03	M	25 + 0.021	8	28.41	54.0	29.0
04	M	35 + 0.025	10	38.41	54.5	36.5
05	M	35 + 0.025	10	38.41	53.5	36.5
06	M	35 + 0.025	10	38.41	54.0	36.5
08	M	50 + 0.025	14	53.90	69.0	49.0
09	M	55 + 0.030	16	59.40	69.0	55.6
10	M	55 + 0.030	16	59.40	76.0	55.6
11	M	75 + 0.030	20	80.00	84.5	74.6

Optional Bore Sizes

Ø G (in)	UNIT SIZE								
	B02	B03	B04	B05	B06	B08	B09	B10	B11
0.6255 ± 0.0005	E	E							
0.8755 ± 0.0005	—	F	E						
1.0005 ± 0.0005	A	A	F	E	E				
1.1255 ± 0.0005			G	F	F	E			
1.1880 ± 0.0005			—	G	G	—			
1.2505 ± 0.0005			J	J	J	—			
1.4385 ± 0.0005			A	A	A	J	E	E	E
1.7505 ± 0.0005						—	F	F	—
1.9380 ± 0.0005						A	G	G	—
2.1880 ± 0.0005							A	A	G
2.4380 ± 0.0005									J
2.9380 ± 0.0005									A





I/P MOTOR ADAPTERS Conveyor Killer “CvK” Series

**NEMA Worm* Gearboxes
Ultra Quiet Aluminum Housing**

Single Stage Units

Motor Frame	UNIT SIZE								
	02	03	04	05	06	08	09	10	11
56C	U	T	T	T	T	Q	Q	Q	Q
143TC/145TC	W	V	V	V	V	R	R	R	R
182TC/184TC		X	X	X	X	T	T	T	T
213TC/215TC						V	V	V	V

GEAR UNIT FEATURES - COLUMN 15 ENTRY

COLUMN 15 ENTRY	Double Extended Input*	Painted Option	Light Washdown Duty Option	Washdown Duty Option	Special Features
-					
G	•				
H	•	•			
P		•			
S				•	
U			•		
Z					•

* Solid shaft extension to standard proportions on non drive end of input



DIMENSIONS STANDARD Conveyor Killer “CvK” Series



NEMA Worm* Gearboxes Ultra Quiet Aluminum Housing

REDUCER

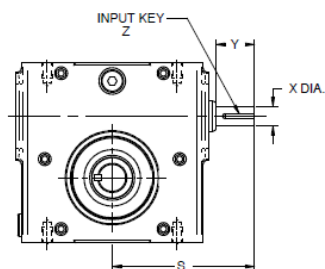

MOTORIZED

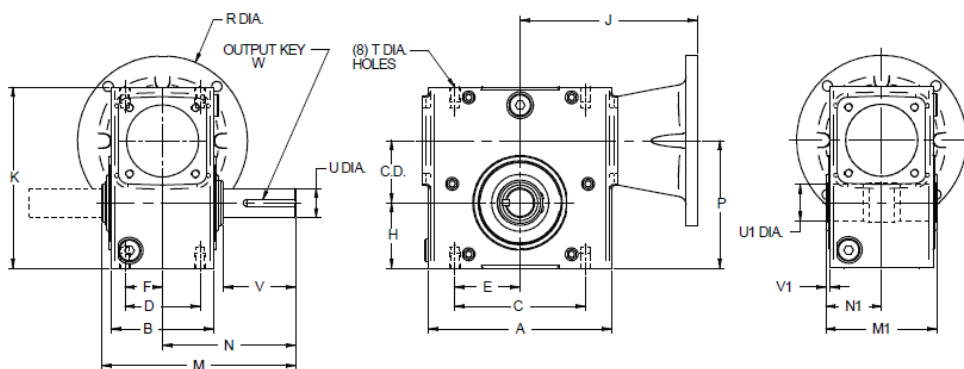

Case Size	C.D.	A	B	C	D	E	F	H	K	M	M1	N	N1	P	T Dia.
02	1.33	4.33	2.76	3.25	2.00	1.63	1.00	1.72	4.66	6.10	3.85	4.00	1.93	3.05	M8 x 0.47
03	1.54	5.23	3.94	4.19	2.75	2.10	1.38	1.91	5.35	6.61	4.25	4.31	2.12	3.45	M8 x 0.47
04	1.75	5.98	3.94	4.19	2.75	2.10	1.38	2.06	5.75	6.65	4.29	4.31	2.15	3.81	M8 x 0.47
05	1.97	6.00	3.94	5.00	2.88	2.50	1.44	2.28	6.38	7.00	4.21	4.69	2.11	4.25	M10 x 0.59
06	2.38	7.00	3.94	5.00	2.88	2.50	1.44	2.50	6.93	7.41	4.25	5.09	2.13	4.88	M10 x 0.59
08	2.62	7.50	5.12	6.38	3.38	3.19	1.69	2.94	7.99	8.58	5.43	5.63	2.72	5.57	M10 x 0.59
09	3.00	9.00	5.12	7.00	4.00	3.50	2.00	3.25	8.88	9.70	5.43	6.75	2.72	6.25	M12 x 0.71
10	3.25	9.05	5.67	7.50	4.00	3.75	2.00	3.50	9.38	10.28	5.98	7.06	2.99	6.75	M12 x 0.71
11	3.54	9.50	5.12	7.50	4.00	3.75	2.00	3.39	9.84	11.34	6.65	7.75	3.33	6.93	M16 x 0.87

Case Size	C.D.	REDUCER					MOTORIZED						OUTPUT SHAFT				W-KEY		WT (LBS)
		X Dia.	Y	SQ.	LC	S	56C/ 143/145TC	182/184TC	213/215TC	J	R Dia.	J	R Dia.	J	R Dia.	U Dia.	U1 Dia.	V	
02	1.33	0.625	1.31	3/16	1.00	4.22	4.74	6.50	NA	NA	NA	NA	0.750	1.000	1.88	0.12	3/16	1.00	9
03	1.54	0.750	1.48	3/16	1.13	4.87	5.92	6.50	6.16	9.00	NA	NA	0.750	1.000	1.99	0.08	3/16	1.13	14
04	1.75	0.750	1.48	3/16	1.13	5.13	6.18	6.50	6.42	9.00	NA	NA	1.000	1.438	1.97	0.08	1/4	1.25	16
05	1.97	0.750	1.48	3/16	1.13	5.20	6.34	6.50	6.58	9.00	NA	NA	1.125	1.438	2.39	0.08	1/4	1.50	18
06	2.38	0.750	1.48	3/16	1.13	5.47	6.77	6.50	7.01	9.00	NA	NA	1.125	1.438	2.77	0.08	1/4	1.88	23
08	2.62	1.188	2.69	1/4	2.25	7.23	7.24	6.50	7.59	9.00	7.59	9.00	1.500	1.938	2.68	0.08	3/8	1.97	40
09	3.00	1.188	2.69	1/4	2.25	7.63	7.64	6.50	7.98	9.00	7.98	9.00	1.500	2.188	3.80	0.08	3/8	2.00	47
10	3.25	1.188	2.69	1/4	2.25	7.64	7.72	6.50	8.06	9.00	8.06	9.00	1.500	2.188	3.83	0.08	3/8	2.25	50
11	3.54	1.188	2.95	1/4	2.62	8.39	8.15	6.50	8.50	9.00	8.50	9.00	1.875	2.938	4.15	0.10	1/2	2.63	70



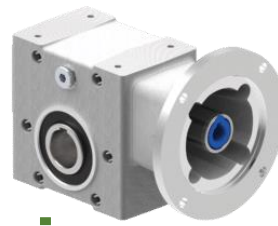

DIMENSIONS BASE Conveyor Killer "CvK" Series

NEMA Worm* Gearboxes Ultra Quiet Aluminum Housing

REDUCER

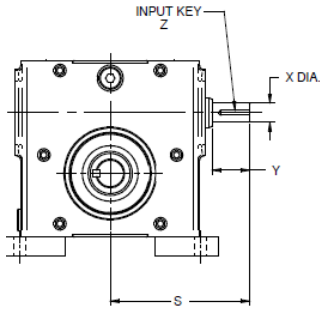

MOTORIZED

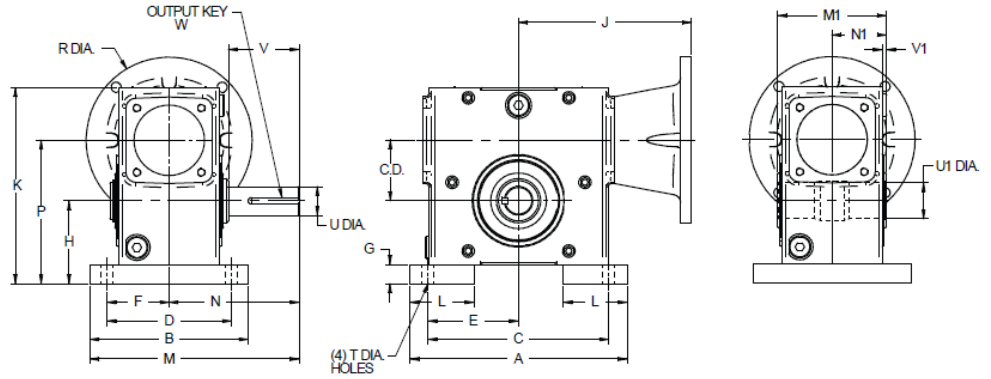

Case Size	C.D	A	B	C	D	E	F	G	H	K	L	M	M1	N	N1	P	T Dia.
02	1.33	5.38	4.19	4.380	3.310	2.190	1.655	0.53	2.25	5.19	1.50	6.09	3.85	4.00	1.93	3.58	11/32
03	1.54	6.44	5.44	5.250	4.312	2.625	2.156	0.59	2.50	5.94	1.50	7.03	4.25	4.31	2.12	4.04	13/32
04	1.75	7.00	5.69	5.750	4.500	2.875	2.250	0.69	2.75	6.44	2.00	7.16	4.29	4.31	2.15	4.50	13/32
05	1.97	7.75	5.94	6.380	4.690	3.190	2.345	0.72	3.00	7.10	2.00	7.66	4.21	4.69	2.11	4.97	15/32
06	2.38	8.50	6.19	7.063	4.875	3.532	2.438	0.75	3.25	7.68	2.50	8.19	4.25	5.09	2.13	5.63	15/32
08	2.62	9.63	6.66	8.000	5.250	4.000	2.625	0.75	3.69	8.74	2.50	8.96	5.43	5.63	2.72	6.31	17/32
09	3.00	10.00	7.50	8.440	5.880	4.220	2.940	0.75	4.00	9.63	2.00	10.50	5.43	6.75	2.72	7.00	17/32
10	3.25	11.19	7.66	9.500	6.125	4.750	3.063	0.88	4.38	10.25	2.50	10.89	5.98	7.06	2.99	7.63	17/32
11	3.54	11.08	7.71	9.500	6.120	4.750	3.060	1.61	5.00	11.45	2.50	11.61	6.65	7.75	3.33	8.54	9/16

Case Size	REDUCER						MOTORIZED						OUTPUT SHAFT				W-KEY		WT (LBS)
	C.D.	INPUT SHAFT X Dia.	Z-KEY Y	SQ.	LG	S	56C/143/145TC J	R Dia.	182/184TC J	R Dia.	213/215TC J	R Dia.	U Dia.	U1 Dia.	V	V1	SQ.	LG	
02	1.33	0.625	1.31	3/16	1.00	4.22	4.74	6.50	NA	NA	NA	NA	0.750	1.000	1.88	0.12	3/16	1.00	10
03	1.54	0.750	1.48	3/16	1.13	4.87	5.92	6.50	6.16	9.00	NA	NA	0.750	1.000	1.99	0.08	3/16	1.13	15
04	1.75	0.750	1.48	3/16	1.13	5.13	6.18	6.50	6.42	9.00	NA	NA	1.000	1.438	1.97	0.08	1/4	1.25	18
05	1.97	0.750	1.48	3/16	1.13	5.20	6.34	6.50	6.58	9.00	NA	NA	1.125	1.438	2.39	0.08	1/4	1.50	20
06	2.38	0.750	1.48	3/16	1.13	5.47	6.77	6.50	7.01	9.00	NA	NA	1.125	1.438	2.77	0.08	1/4	1.88	25
08	2.62	1.188	2.69	1/4	2.25	7.23	7.24	6.50	7.59	9.00	7.59	9.00	1.500	1.938	2.68	0.08	3/8	1.97	43
09	3.00	1.188	2.69	1/4	2.25	7.63	7.64	6.50	7.98	9.00	7.98	9.00	1.500	2.188	3.80	0.08	3/8	2.00	50
10	3.25	1.188	2.69	1/4	2.25	7.64	7.72	6.50	8.06	9.00	8.06	9.00	1.500	2.188	3.83	0.08	3/8	2.25	54
11	3.54	1.188	2.95	1/4	2.62	8.39	8.15	6.50	8.50	9.00	8.50	9.00	1.875	2.938	4.15	0.10	1/2	2.63	75



DIM BASE REVERSE Conveyor Killer “CvK” Series



NEMA Worm* Gearboxes Ultra Quiet Aluminum Housing

REDUCER

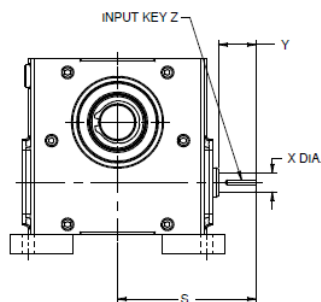

MOTORIZED

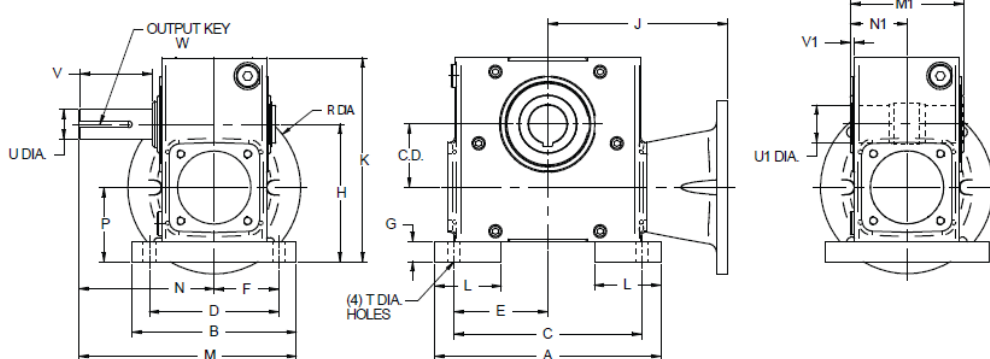

Case Size	C.D.	A	B	C	D	E	F	G	H	K	L	M	M1	N	N1	P	T Dia.
02	1.33	5.38	4.19	4.380	3.310	2.190	1.655	0.53	3.47	5.19	1.50	6.09	3.85	4.00	1.93	2.14	11/32
03	1.54	6.44	5.44	5.250	4.312	2.625	2.156	0.59	4.03	5.94	1.50	7.03	4.25	4.31	2.12	2.49	13/32
04	1.75	7.00	5.69	5.750	4.500	2.875	2.250	0.69	4.38	6.44	2.00	7.16	4.29	4.31	2.15	2.63	13/32
05	1.97	7.75	5.94	6.380	4.690	3.190	2.345	0.72	4.82	7.10	2.00	7.66	4.21	4.69	2.11	2.85	15/32
06	2.38	8.50	6.19	7.063	4.875	3.532	2.438	0.75	5.18	7.68	2.50	8.19	4.25	5.09	2.13	2.80	15/32
08	2.62	9.63	6.66	8.000	5.250	4.000	2.625	0.75	5.80	8.74	2.50	8.96	5.43	5.63	2.72	3.18	17/32
09	3.00	10.00	7.50	8.440	5.880	4.220	2.940	0.75	6.38	9.63	2.00	10.50	5.43	6.75	2.72	3.38	17/32
10	3.25	11.19	7.66	9.500	6.125	4.750	3.063	0.88	6.75	10.25	2.50	10.89	5.98	7.06	2.99	3.50	17/32
11	3.54	11.08	7.71	9.500	6.120	4.750	3.060	1.61	8.07	11.45	2.50	11.61	6.65	7.75	3.33	4.53	9/16

Case Size	REDUCER						MOTORIZED						OUTPUT SHAFT				W-KEY		WT (lbs)
	C.D.	INPUT SHAFT		Z-KEY		56C/143/145TC		182/184TC		213/215TC		U Dia.	U1 Dia.	V	V1	SQ.	LG		
		X Dia.	Y	SQ.	LG	S	J	R Dia.	J	R Dia.	J	R Dia.							
02	1.33	0.625	1.31	3/16	1.00	4.22	4.74	6.50	NA	NA	NA	NA	0.750	1.000	1.88	0.12	3/16	1.00	10
03	1.54	0.750	1.48	3/16	1.13	4.87	5.92	6.50	6.16	9.00	NA	NA	0.750	1.000	1.99	0.08	3/16	1.13	15
04	1.75	0.750	1.48	3/16	1.13	5.13	6.18	6.50	6.42	9.00	NA	NA	1.000	1.438	1.97	0.08	1/4	1.25	18
05	1.97	0.750	1.48	3/16	1.13	5.20	6.34	6.50	6.58	9.00	NA	NA	1.125	1.438	2.39	0.08	1/4	1.50	20
06	2.38	0.750	1.48	3/16	1.13	5.47	6.77	6.50	7.01	9.00	NA	NA	1.125	1.438	2.77	0.08	1/4	1.88	25
08	2.62	1.188	2.69	1/4	2.25	7.23	7.24	6.50	7.59	9.00	7.59	9.00	1.500	1.938	2.68	0.08	3/8	1.97	43
09	3.00	1.188	2.69	1/4	2.25	7.63	7.64	6.50	7.98	9.00	7.98	9.00	1.500	2.188	3.80	0.08	3/8	2.00	50
10	3.25	1.188	2.69	1/4	2.25	7.64	7.72	6.50	8.06	9.00	8.06	9.00	1.500	2.188	3.83	0.08	3/8	2.25	54
11	3.54	1.188	2.95	1/4	2.62	8.39	8.15	6.50	8.50	9.00	8.50	9.00	1.875	2.938	4.15	0.10	1/2	2.63	75



DIM VERT HIGH & LOW Conveyor Killer "CvK" Series

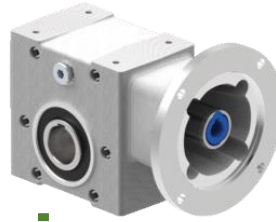

NEMA Worm* Gearboxes Ultra Quiet Aluminum Housing

REDUCER

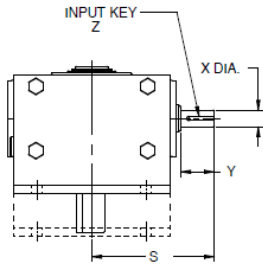

MOTORIZED

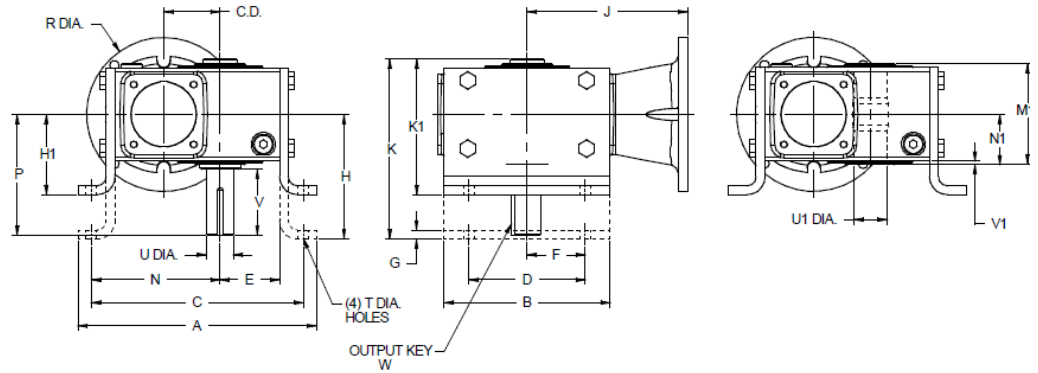

Case Size	C.D.	A	B	C	D	E	F	G	H	H1	K	K1	M1	N	N1	P	T Dia.
02	1.33	7.09	4.33	6.15	3.25	1.72	1.63	0.25	3.56	2.31	5.66	4.41	3.85	3.69	1.93	4.00	11/32
03	1.54	8.04	5.23	6.98	4.00	1.91	2.00	0.25	4.38	3.00	6.68	5.30	4.25	4.26	2.12	4.31	13/32
04	1.75	8.44	5.98	7.38	4.00	2.06	2.00	0.31	4.38	3.00	6.72	5.34	4.29	4.51	2.15	4.31	13/32
05	1.97	9.50	6.00	8.38	4.88	2.28	2.44	0.38	4.88	3.13	7.19	5.44	4.21	5.10	2.11	4.69	15/32
06	2.38	10.06	7.00	8.95	4.88	2.50	2.44	0.38	5.25	3.38	7.57	5.70	4.25	5.44	2.13	5.09	15/32
08	2.62	11.69	7.50	10.13	5.75	2.94	2.88	0.38	5.59	3.63	8.54	6.58	5.43	6.14	2.72	5.63	17/32
09	3.00	13.25	9.00	11.14	6.00	3.25	3.00	0.38	5.88	3.94	8.83	6.89	5.43	6.76	2.72	6.75	17/32
10	3.25	13.37	9.05	11.87	6.13	3.50	3.07	0.50	6.25	4.69	9.47	7.91	5.98	7.12	2.99	7.06	17/32
11	3.54	16.84	9.50	14.88	7.88	3.39	3.94	0.50	7.50	5.00	11.09	8.59	6.65	8.99	3.33	7.75	9/16

Case Size	REDUCER						MOTORIZED						OUTPUT SHAFT				W-KEY		WT (lbs)
	C.D.	X Dia.	Y	SQ.	LG	S	J	R Dia.	J	R Dia.	J	R Dia.	U Dia.	U1 Dia.	V	V1	SQ.	LG	
02	1.33	0.625	1.31	3/16	1.00	4.22	4.74	6.50	NA	NA	NA	NA	0.750	1.000	1.88	0.12	3/16	1.00	10
03	1.54	0.750	1.48	3/16	1.13	4.87	5.92	6.50	6.16	9.00	NA	NA	0.750	1.000	1.99	0.08	3/16	1.13	15
04	1.75	0.750	1.48	3/16	1.13	5.13	6.18	6.50	6.42	9.00	NA	NA	1.000	1.438	1.97	0.08	1/4	1.25	18
05	1.97	0.750	1.48	3/16	1.13	5.20	6.34	6.50	6.58	9.00	NA	NA	1.125	1.438	2.39	0.08	1/4	1.50	20
06	2.38	0.750	1.48	3/16	1.13	5.47	6.77	6.50	7.01	9.00	NA	NA	1.125	1.438	2.77	0.08	1/4	1.88	25
08	2.62	1.188	2.69	1/4	2.25	7.23	7.24	6.50	7.59	9.00	7.59	9.00	1.500	1.938	2.68	0.08	3/8	1.97	44
09	3.00	1.188	2.69	1/4	2.25	7.63	7.64	6.50	7.98	9.00	7.98	9.00	1.500	2.188	3.80	0.08	3/8	2.00	51
10	3.25	1.188	2.69	1/4	2.25	7.64	7.72	6.50	8.06	9.00	8.06	9.00	1.500	2.188	3.83	0.08	3/8	2.25	55
11	3.54	1.188	2.95	1/4	2.62	8.39	8.15	6.50	8.50	9.00	8.50	9.00	1.875	2.938	4.15	0.10	1/2	2.63	76



DIM OUTPUT BRACKET Conveyor Killer “CvK” Series



**NEMA Worm* Gearboxes
Ultra Quiet Aluminum Housing**

REDUCER

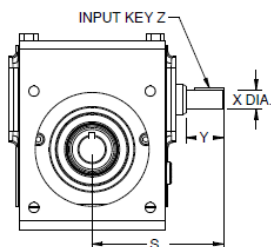

MOTORIZED

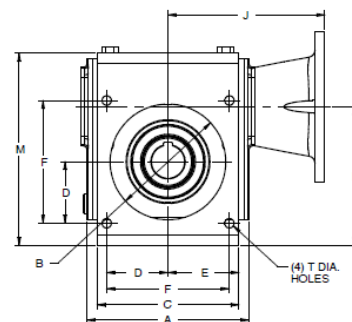
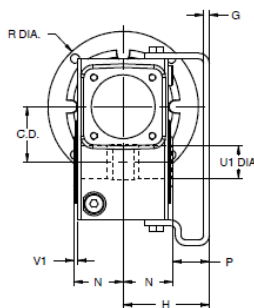
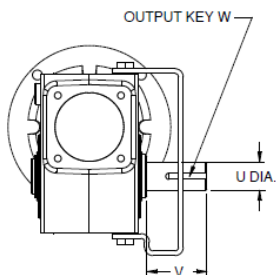

Case Size	C.D.	A	B	C	D	E	F	G	H	K	M	N	P	T Dia.
02	1.33	4.33	3.62	4.25	1.77	2.13	3.54	0.19	3.00	3.75	5.55	1.93	1.07	11/32
03	1.54	5.23	3.62	4.75	1.77	2.38	3.54	0.19	3.56	4.07	6.16	2.12	1.44	11/32
04	1.75	5.98	4.06	4.81	2.08	2.41	4.16	0.19	3.50	4.53	6.66	2.15	1.35	11/32
05	1.97	6.00	4.50	5.75	2.30	2.88	4.60	0.19	3.75	5.15	7.47	2.11	1.64	13/32
06	2.38	7.00	5.00	6.13	2.65	3.07	5.30	0.25	3.72	6.00	8.30	2.13	1.59	13/32
08	2.62	7.50	6.00	7.18	2.83	3.59	5.66	0.25	4.06	6.57	9.25	2.72	1.34	13/32
09	3.00	9.00	7.00	8.50	3.18	4.25	6.36	0.25	4.50	7.14	10.02	2.72	1.78	13/32
10	3.25	9.05	7.00	8.50	3.54	4.25	7.07	0.25	5.25	8.04	10.91	2.99	2.26	9/16
11	3.54	9.50	8.56	9.50	3.54	4.75	7.07	0.25	5.25	9.19	12.35	3.33	1.92	9/16

Case Size	C.D.	REDUCER					MOTORIZED						OUTPUT SHAFT				W-KEY		WT (lbs)
		INPUT SHAFT	Z-KEY				56C/143/145TC		182/184TC		213/215TC								
		X Dia.	Y	SQ.	LG	S	J	R Dia.	J	R Dia.	J	R Dia.	U Dia.	U1 Dia.	V	V1	SQ.	LG	
02	1.33	0.625	1.31	3/16	1.00	4.22	4.74	6.50	NA	NA	NA	NA	0.750	1.000	1.88	0.12	3/16	1.00	9
03	1.54	0.750	1.48	3/16	1.13	4.87	5.92	6.50	6.16	9.00	NA	NA	0.750	1.000	1.99	0.08	3/16	1.13	14
04	1.75	0.750	1.48	3/16	1.13	5.13	6.18	6.50	6.42	9.00	NA	NA	1.000	1.438	1.97	0.08	1/4	1.25	16
05	1.97	0.750	1.48	3/16	1.13	5.20	6.34	6.50	6.58	9.00	NA	NA	1.125	1.438	2.39	0.08	1/4	1.50	18
06	2.38	0.750	1.48	3/16	1.13	5.47	6.77	6.50	7.01	9.00	NA	NA	1.125	1.438	2.77	0.08	1/4	1.88	23
08	2.62	1.188	2.69	1/4	2.25	7.23	7.24	6.50	7.59	9.00	7.59	9.00	1.500	1.938	2.68	0.08	3/8	1.97	40
09	3.00	1.188	2.69	1/4	2.25	7.63	7.64	6.50	7.98	9.00	7.98	9.00	1.500	2.188	3.80	0.08	3/8	2.00	47
10	3.25	1.188	2.69	1/4	2.25	7.64	7.72	6.50	8.06	9.00	8.06	9.00	1.500	2.188	3.83	0.08	3/8	2.25	50
11	3.54	1.188	2.95	1/4	2.62	8.39	8.15	6.50	8.50	9.00	8.50	9.00	1.875	2.938	4.15	0.10	1/2	2.63	70



High Precision Right Angle Gearboxes

Spiral Bevel Gearing Steel Housing

Spiral Bevel "SpB" Series

- Various housing design
- Stainless – Available as an option
- Carbon Steel
- Various output options
- High torque, High efficiency
Long service life
- Reduced backlash
- Maintenance free
- Flexible mounting dimensions

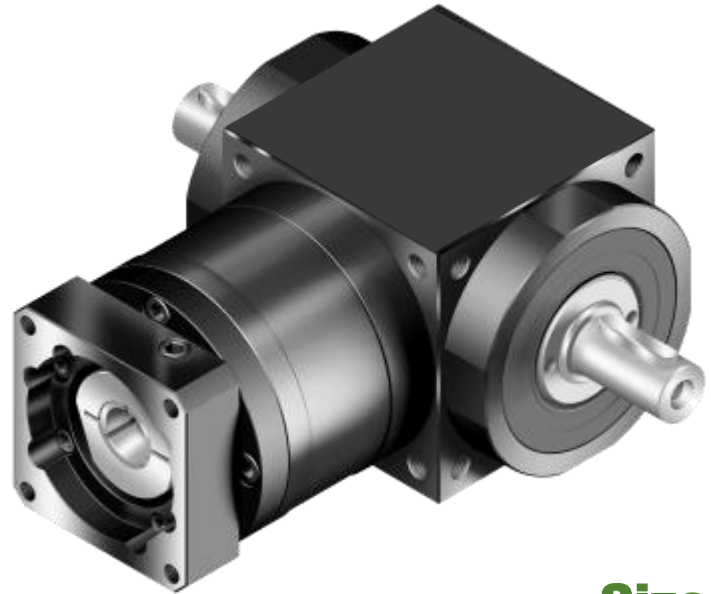

Sizes

- SpB065T**
- SpB075T**
- SpB090T**
- SpB110T**
- SpB140T**
- SpB170T**
- SpB210T**
- SpB240T**
- SpB280T**

- **CUSTOM RATIOS**
- **CUSTOM BORES**
- **CUSTOM ADAPTERS**
- **CUSTOM MOUNTING**
- **CUSTOM SEALS, etc.**

Fangtooth will tackle any solution by making a custom to fit your exact requirement



CALL TODAY



Fangtooth Spiral Bevel "SpB"
Right Angle Gearboxes
Gearbox Technical Information

www.fangtooth-linear.com

ORDERING CODES Spiral Bevel "SpB" Series

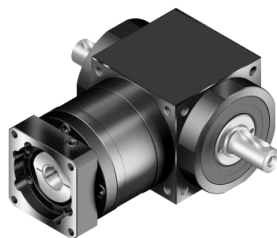

High Precision
Right Angle Gearboxes

Model: SpB090SB-S1.5Q-18MHHK/MS2N04

Gearbox Series	SpB – Spiral Bevel	Gearbox Input	SIP – Single Input DIP – Dual Input Motor Model – Mounting Kit
Gearbox Size	065 – 65 mm Housing 075 – 75 mm Housing 090 – 90 mm Housing 110 – 110 mm Housing 140 – 140 mm Housing 170 – 170 mm Housing 210 – 210 mm Housing 240 – 240 mm Housing 280 – 280 mm Housing	Gearbox Output Type	K – Keyed S – Smooth D – Shrink Disc
Gearbox Drive Type	SB – Spiral Bevel	Gearbox Output Location	HH – Hollow Bore Through H1 – Hollow Bore "1" side H2 – Hollow Bore "2" side ZZ – Solid Shaft, Double Ext Z1 – Solid Shaft "1" side Z2 – Solid Shaft "2" side
Gearbox Backlash	S – Standard	Gearbox Output Size	##M – size in mm
Gearbox Ratio	1.0 – 1:1 3.0 – 3:1 1.5 – 1.5:1 4.0 – 4:1 2.0 – 2:1 5.0 – 5:1	Gearbox Mounting	Q – Standard

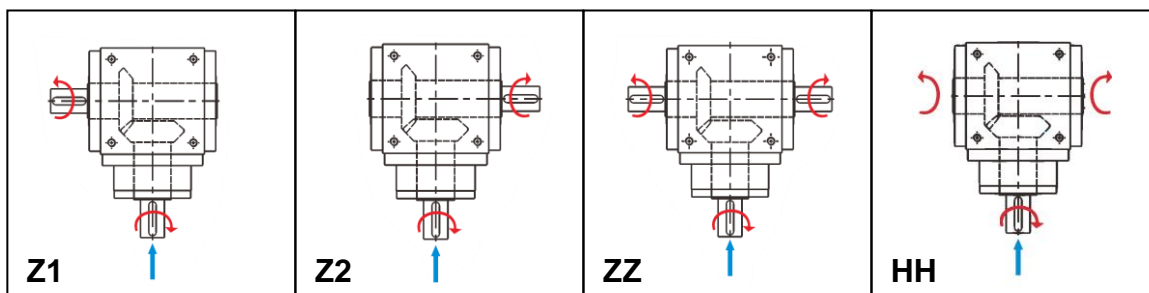

RATINGS

Spiral Bevel “SpB” Series

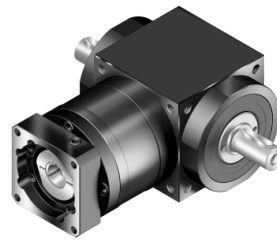

High Precision Right Angle Gearboxes

		SpB Size									
		Ratio	065	075	090	110	140	170	210	240	280
Nominal Output Torque T_{2N}	Nm	1	25	45	78	150	360	585	1,300	2,150	3,200
		1.5	25	45	78	150	360	585	1,300	2,150	3,200
		2	24	42	68	150	330	544	1,220	2,010	3,050
		3	18	33	54	120	270	450	1,020	1,650	2,850
		4	13	28	48	100	224	376	860	1,410	2,300
	5	12	25	40	85	196	320	740	1,210	2,000	
Max. Acceleration Torque T_{2B}	Nm	1~5	1.5 times of Nominal Output Torque								
Max. Acceleration Input Speed n_{1B}	rpm	1~5	7,500	6,500	5,500	4,500	3,500	3,000	2,200	2,000	1,700
Standard Backlash ^B	arcmin	1~5	≤6	≤6	≤6	≤6	≤6	≤6	≤6	≤6	≤6
Max. Radial Load F_{1rB} ^C Input d1	N	1~5	700	950	1,450	2,100	2,700	3,800	7,800	9,600	10,500
Max. Radial Load F_{2rB} ^D Output d2	N	1~5	900	1,100	1,700	2,700	4,800	6,600	11,500	16,000	18,000
Max. Axial Load F_{1aB} ^C Input d1	N	1~5	350	425	725	1,050	1,350	1,900	3,900	4,800	5,250
Max. Axial Load F_{2aB} ^D Output d2	N	1~5	450	550	850	1,350	2,400	3,300	5,750	8,500	9,000
Efficiency η	%	1~5	≥98%								
Operating Temp	°C	1~5	-10°C ~ 90°C								
Lubrication			Synthetic lubrication oils								
Noise Level ^E	dB (A)	1~5	≤68	≤70	≤74	≤76	≤77	≤78	≤80	≤82	≤83
Mass Moments of Inertia J_1	kg · cm ²	1	0.51	1.30	3.16	7.70	23.57	58.99	195.40	369.34	799.12
		1.5	0.64	1.16	2.82	6.74	19.37	49.28	155.45	283.58	595.78
		2	0.44	1.11	2.70	6.31	17.75	45.35	140.24	249.74	511.76
		3	0.43	1.09	2.66	6.17	17.18	44.01	134.95	237.71	483.06
		4	0.43	1.09	2.65	6.13	17.06	43.70	133.58	234.72	476.26
		5	0.43	1.09	2.65	6.12	17.02	43.60	133.14	233.67	473.58

Approx Weights (kg)

SpB Size 065 – 2.6 kg
 SpB Size 075 – 4.1 kg
 SpB Size 090 – 6.7 kg
 SpB Size 110 – 11.5 kg
 SpB Size 140 – 19.5 kg
 SpB Size 170 – 34.2 kg
 SpB Size 210 – 65.1 kg
 SpB Size 240 – 96.6 kg
 SpB Size 280 – 153.4 kg



DIMENSIONS 3-WAY Spiral Bevel "SpB" Series

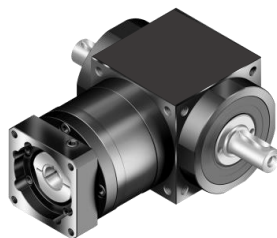

High Precision
Right Angle Gearboxes

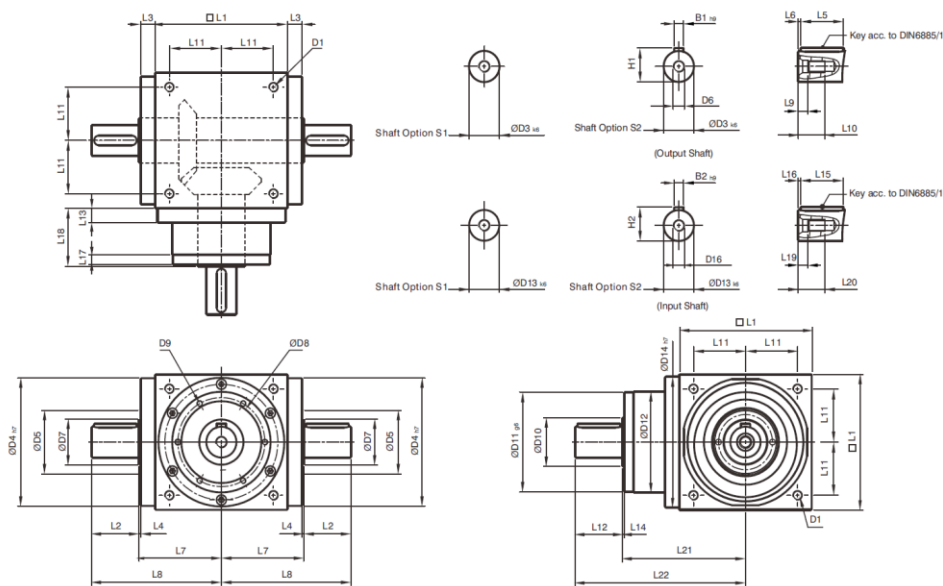

Dimension	065	075	090	110	140	170	210	240	280
D1	M4	M6	M6	M8	M10	M12	M16	M16	M16
D3 k6	13	16	18	22	32	40	50	55	60
D4 h7	63	73	88	108	135	165	205	235	275
D5	31	35	43	53	68	83	104	124	144
D6	M4	M5	M5	M8	M12	M16	M16	M16	M20
D7	21	22	28	33	47	55	75	85	110
D8	53	62	76	95	92	114	142	160	176
D9	4xM4xL7	4xM5xL8	4xM5xL8	6xM6xL10	6xM6xL10	6xM8xL12.5	6xM8xL12.5	6xM8xL12.5	6xM10xL15
D10	15.4	20.4	25.8	35.8	49.8	59.3	79.3	92.3	102.3
D11 g6	62.9	72.9	87	107	103	127	158	178	198
D12	62	72	86	106	104	128	160	180	200
D13 k6	13	16	18	22	32	40	50	55	60
D14 h7	63	73	88	108	135	165	205	235	275
D16	M4	M5	M5	M8	M12	M16	M16	M16	M20
L1	65	75	90	110	140	170	210	240	280
L2	19.5	30	35	40	50	60	75	85	110
L3	13	14.5	15	15	15	15	20	25	25
L4	2	2	2	2	2	2	2	2	2
L5	16	25	28	32	45	50	70	80	100
L6	2	2.5	3.5	4	2.5	5	2.5	2.5	5
L7	47.5	54	62	72	87	102	127	147	167
L8	67	84	97	112	137	162	202	232	277
L9	4.5	4.8	4.8	7.2	10	12	12	12	15
L10	10	12.5	12.5	19	28	36	36	36	42
L11	27	30	36	44	55	67	85	95	110
L12	19.5	30	35	40	50	60	75	85	110
L13	13	15	15	15	15	15	20	25	25
L14	2	2	2	2	2	2	2	2	2
L15	16	25	28	32	45	50	70	80	100
L16	2	2.5	3.5	4	2.5	5	2.5	2.5	5
L17	6	8	8	8	10	10	10	10	10
L18	43	52.5	55	60	60	70	90	105	120
L19	4.5	4.8	4.8	7.2	10	12	12	12	15
L20	10	12.5	12.5	19	28	36	36	36	42
L21	75.5	90	100	115	130	155	195	225	260
L22	95	120	135	155	180	215	270	310	370
B1 h9	5	5	6	6	10	12	14	16	18
B2 h9	5	5	6	6	10	12	14	16	18
H1	15	18	20.5	24.5	35	43	53.5	59	64
H2	15	18	20.5	24.5	35	43	53.5	59	64



DIMENSIONS 2-WAY Spiral Bevel "SpB" Series

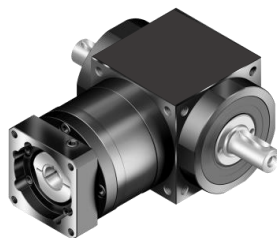

High Precision
Right Angle Gearboxes

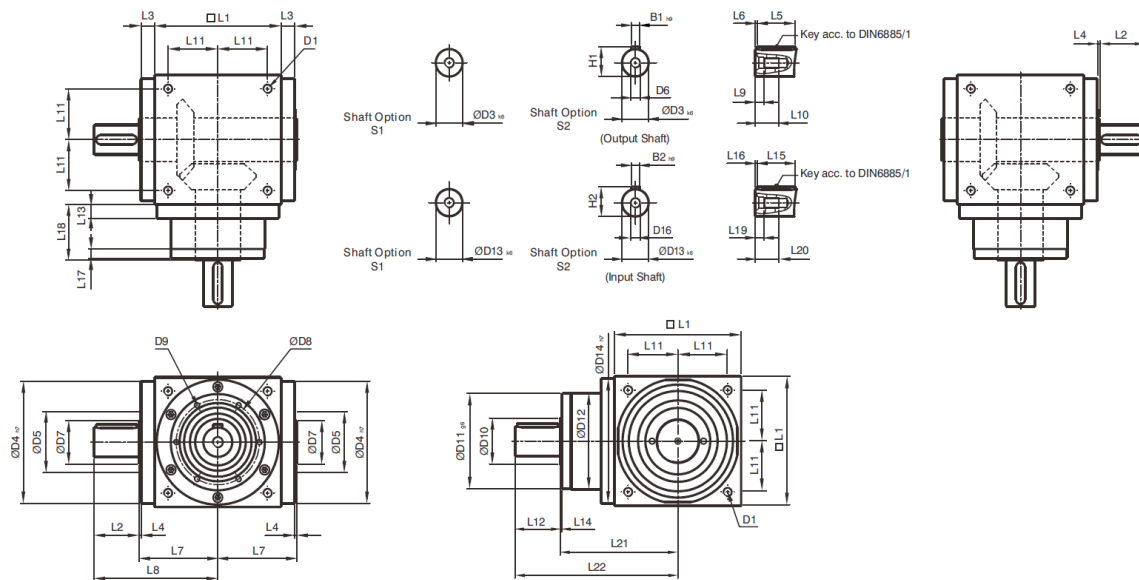

Dimension	065	075	090	110	140	170	210	240	280
D1	M4	M6	M6	M8	M10	M12	M16	M16	M16
D3 _{k6}	13	16	18	22	32	40	50	55	60
D4 _{h7}	63	73	88	108	135	165	205	235	275
D5	31	35	43	53	68	83	104	124	144
D6	M4	M5	M5	M8	M12	M16	M16	M16	M20
D7	21	22	28	33	47	55	75	85	110
D8	53	62	76	95	92	114	142	160	176
D9	4xM4xL7	4xM5xL8	4xM5xL8	6xM6xL10	6xM6xL10	6xM8xL12.5	6xM8xL12.5	6xM8xL12.5	6xM10xL15
D10	15.4	20.4	25.8	35.8	49.8	59.3	79.3	92.3	102.3
D11 _{g6}	62.9	72.9	87	107	103	127	158	178	198
D12	62	72	86	106	104	128	160	180	200
D13 _{k6}	13	16	18	22	32	40	50	55	60
D14 _{h7}	63	73	88	108	135	165	205	235	275
D16	M4	M5	M5	M8	M12	M16	M16	M16	M20
L1	65	75	90	110	140	170	210	240	280
L2	19.5	30	35	40	50	60	75	85	110
L3	13	14.5	15	15	15	15	20	25	25
L4	2	2	2	2	2	2	2	2	2
L5	16	25	28	32	45	50	70	80	100
L6	2	2.5	3.5	4	2.5	5	2.5	2.5	5
L7	47.5	54	62	72	87	102	127	147	167
L8	67	84	97	112	137	162	202	232	277
L9	4.5	4.8	4.8	7.2	10	12	12	12	15
L10	10	12.5	12.5	19	28	36	36	36	42
L11	27	30	36	44	55	67	85	95	110
L12	19.5	30	35	40	50	60	75	85	110
L13	13	15	15	15	15	15	20	25	25
L14	2	2	2	2	2	2	2	2	2
L15	16	25	28	32	45	50	70	80	100
L16	2	2.5	3.5	4	2.5	5	2.5	2.5	5
L17	6	8	8	8	10	10	10	10	10
L18	43	52.5	55	60	60	70	90	105	120
L19	4.5	4.8	4.8	7.2	10	12	12	12	15
L20	10	12.5	12.5	19	28	36	36	36	42
L21	75.5	90	100	115	130	155	195	225	260
L22	95	120	135	155	180	215	270	310	370
B1 _{h9}	5	5	6	6	10	12	14	16	18
B2 _{h9}	5	5	6	6	10	12	14	16	18
H1	15	18	20.5	24.5	35	43	53.5	59	64
H2	15	18	20.5	24.5	35	43	53.5	59	64



DIMENSIONS SHRINK DISC Spiral Bevel "SpB" Series

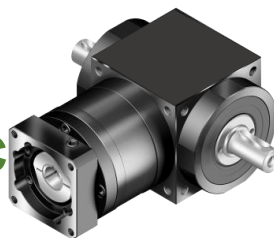

High Precision
Right Angle Gearboxes

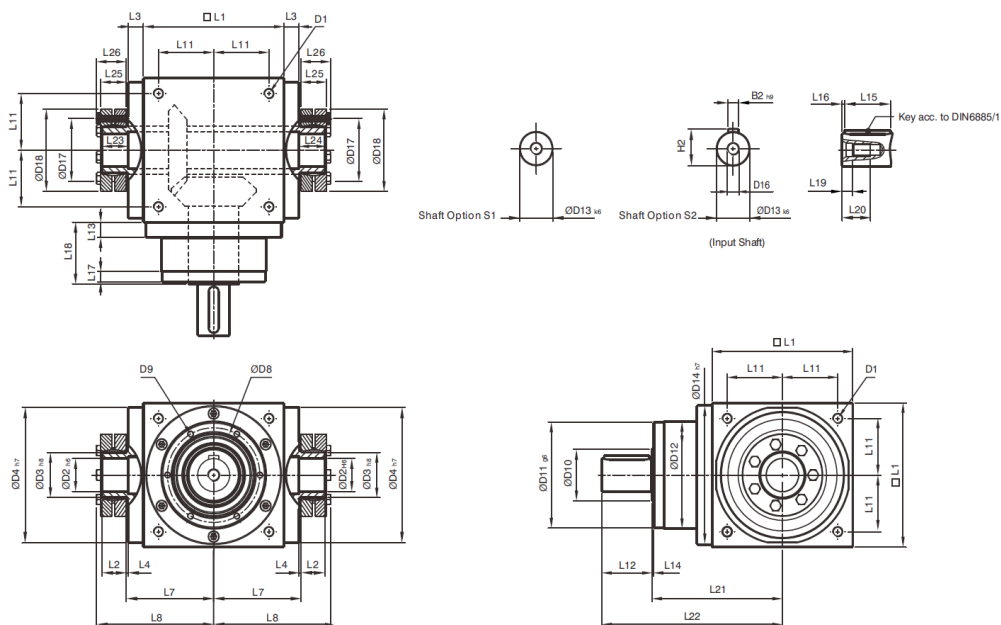

Dimension	065	075	090	110	140	170	210	240	280
D1	M4	M6	M6	M8	M10	M12	M16	M16	M16
D2 H6	13	14	18	22	32	40	50	55	60
D3 h8	16	16	22	25	44	50	62	68	75
D4 h7	63	73	88	108	135	165	205	235	275
D8	53	62	76	95	92	114	142	160	176
D9	4xM4xL7	4xM5xL8	4xM5xL8	6xM6xL10	6xM6xL10	6xM8xL12.5	6xM8xL12.5	6xM8xL12.5	6xM10xL15
D10	15.4	20.4	25.8	35.8	49.8	59.3	79.3	92.3	102.3
D11 g6	62.9	72.9	87	107	103	127	158	178	198
D12	62	72	86	106	104	128	160	180	200
D13 k6	13	16	18	22	32	40	50	55	60
D14 h7	63	73	88	108	135	165	205	235	275
D16	M4	M5	M5	M8	M12	M16	M16	M16	M20
D17	26	26	36	38	61	70	86	86	100
D18	41	41	50	50	80	90	110	115	138
L1	65	75	90	110	140	170	210	240	280
L2	14	14	18	18	24	26	29	29	30.5
L3	13	14.5	15	15	15	15	20	25	25
L4	2	2	2	2	2	2	2	2	2
L7	47.5	54	62	72	87	102	127	147	167
L8	66	72.5	85	95	116.5	133.5	161.5	181.5	205
L11	27	30	36	44	55	67	85	95	110
L12	19.5	30	35	40	50	60	75	85	110
L13	13	15	15	15	15	15	20	25	25
L14	2	2	2	2	2	2	2	2	2
L15	16	25	28	32	45	50	70	80	100
L16	2	2.5	3.5	4	2.5	5	2.5	2.5	5
L17	6	8	8	8	10	10	10	10	10
L18	43	52.5	55	60	60	70	90	105	120
L19	4.5	4.8	4.8	7.2	10	12	12	12	15
L20	10	12.5	12.5	19	28	36	36	36	42
L21	75.5	90	100	115	130	155	195	225	260
L22	95	120	135	155	180	215	270	310	370
L23	15	15	20	20	26	28	31	31	32.5
L24	15	15	20	20	26	28	31	31	32.5
L25	15	15	19.5	19.5	25.5	27.5	30.5	30.5	32.5
L26	18.5	18.5	23	23	29.5	31.5	34.5	34.5	38
B2 h9	5	5	6	6	10	12	14	16	18
H2	15	18	20.5	24.5	35	43	53.5	59	64



DIMENSIONS HOLLOW Spiral Bevel "SpB" Series

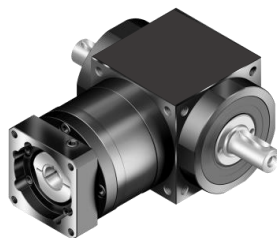

High Precision
Right Angle Gearboxes

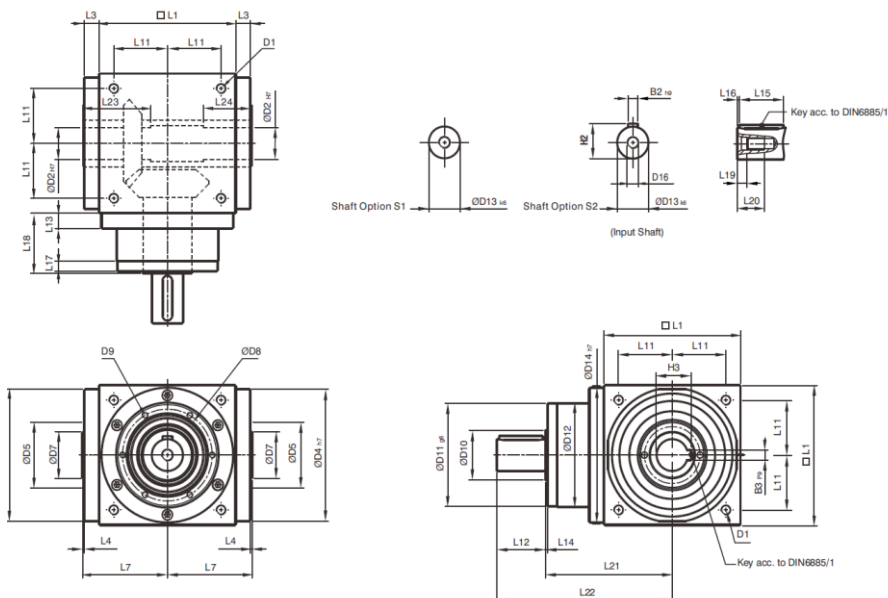

Dimension	065	075	090	110	140	170	210	240	280
D1	M4	M6	M6	M8	M10	M12	M16	M16	M16
D2 H7	13	14	18	22	32	40	50	55	60
D4 h7	63	73	88	108	135	165	205	235	275
D5	31	35	43	53	68	83	104	124	144
D7	21	22	28	33	47	55	75	85	110
D8	53	62	76	95	92	114	142	160	176
D9	4xM4xL7	4xM5xL8	4xM5xL8	6xM6xL10	6xM6xL10	6xM8xL12.5	6xM8xL12.5	6xM8xL12.5	6xM10xL15
D10	15.4	20.4	25.8	35.8	49.8	59.3	79.3	92.3	102.3
D11 g6	62.9	72.9	87	107	103	127	158	178	198
D12	62	72	86	106	104	128	160	180	200
D13 k6	13	16	18	22	32	40	50	55	60
D14 h7	63	73	88	108	135	165	205	235	275
D16	M4	M5	M5	M8	M12	M16	M16	M16	M20
L1	65	75	90	110	140	170	210	240	280
L3	13	14.5	15	15	15	15	20	25	25
L4	2	2	2	2	2	2	2	2	2
L7	47.5	54	62	72	87	102	127	147	167
L11	27	30	36	44	55	67	85	95	110
L12	19.5	30	35	40	50	60	75	85	110
L13	13	15	15	15	15	15	20	25	25
L14	2	2	2	2	2	2	2	2	2
L15	16	25	28	32	45	50	70	80	100
L16	2	2.5	3.5	4	2.5	5	2.5	2.5	5
L17	6	8	8	8	10	10	10	10	10
L18	43	52.5	55	60	60	70	90	105	120
L19	4.5	4.8	4.8	7.2	10	12	12	12	15
L20	10	12.5	12.5	19	28	36	36	36	42
L21	75.5	90	100	115	130	155	195	225	260
L22	95	120	135	155	180	215	270	310	370
L23	40	47	52	53	70	80	95	115	115
L24	30	32	35	35	50	55	65	80	80
B2 h9	5	5	6	6	10	12	14	16	18
B3 P9	5	5	6	6	10	12	14	16	18
H2	15	18	20.5	24.5	35	43	53.5	59	64
H3	15.3	16.3	20.8	24.8	35.3	43.3	53.8	59.3	64.4





MOTORS & BRAKEMOTORS

Standard Sizes 1/6 HP to 30 HP 230/460V/60Hz/3ph

This catalog contains standard NORD & WEG/Watt manufactured induction motors and brakemotors from 0.16 to 30hp. Included are motor standard NEMA and mounting dimensions. For motors with higher powers, hazardous location, and other enclosures please contact us.

They can be well suited for constant torque applications and will safely operate over a frequency range of 0Hz to 120Hz. Each motor can be supplied with a wide range of options to customize the motor for a wide range of applications and operating demands.

Features and Benefits

- Threaded cable entry holes
- Lip seals on both shaft ends
- Sealed and gasketed terminal boxes.
- Continuous Duty (S1) / Premium Efficient (IE3)
- Non-ventilated (TENV).
- Common 50 Hz and 60 Hz voltages.
- Inverter/vector duty wiring and insulation.
- Rated for voltage spikes per NEMA MG1, section 31.4.4.2
- Moisture resistant varnished dipped windings.

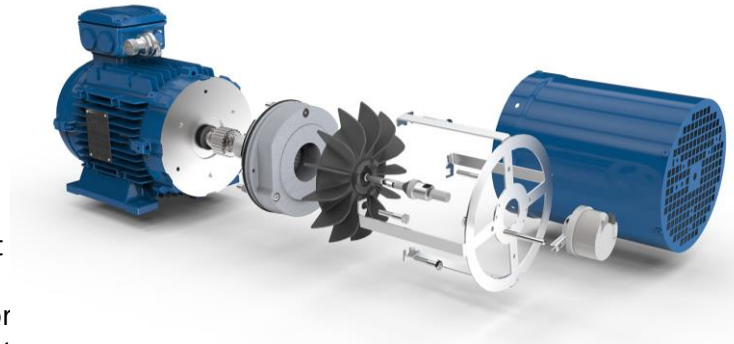

- BRAKES
- FANS
- ENCODERS
- POWER CONNECTOS

Fangtooth will tackle any solution by making a custom to fit your exact requirement

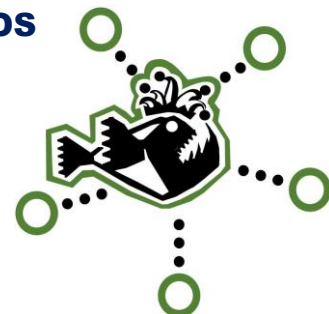

CALL TODAY



ORDERING CODES

Motors “Mtr” Series



Motors & Brakemotors











Motor Size	Without Brake	With Brake
0016-56C - 0.16 hp	[Code 0016]	[Code 0016BR]
0025-56C - 0.25 hp	[Code 0025]	[Code 0025BR]
0033-56C - 0.33 hp	[Code 0033]	[Code 0033BR]
0050-56C - 0.50	[Code 0050]	[Code 0050BR]
0075-56C - 0.75 hp	[Code 0016]	[Code 0016BR]
A100-56C - 1.00 hp	[Code A100]	[Code A100BR]
B100-143TC - 1.00	[Code B100]	[Code B100BR]
0150-145TC - 1.50 hp	[Code 0150]	[Code 0150BR]
0200-145TC - 2.00 hp	[Code 0200]	[Code 0200BR]
0300-182TC - 3.00 hp	[Code 0300]	[Code 0300BR]
0500-184TC - 5.00 hp	[Code 0500]	[Code 0500BR]
0750-213TC - 7.50 hp	[Code 0750]	[Code 0750BR]
1000-215TC - 10.00 hp	[Code 1000]	[Code 1000BR]
1500-254TC - 15.00 hp	[Code 1500]	[Code 1500BR]
2000-256TC - 20.00 hp	[Code 2000]	[Code 2000BR]
2500-286TC - 25.00 hp	[Code 2500]	[Code 2500BR]
3000-286TC - 30.00 hp	[Code 3000]	[Code 3000BR]



RATINGS

Motors “MTR” Series

Motors & Brakemotors

P _n Full Load Power		Eff. Class	n _n Full-Load Speed	I _n Full-Load Current		I _a /I _n Locked Rotor Current Ratio	NEMA Code Letter	T _n Full-Load Torque	T _a /T _n Locked Rotor Torque Ratio	T _k /T _n Break Down Torque Ratio	pf Power Factor	η Full Load Efficiency	J _m Rotor Inertia	Wt. Weight
[hp]	[kW]			[A]	[A]									
0.16	0.12	-	1700	0.88	0.44	250%	F	5.93	2.7	3.5	0.66	52.0%	0.0050	7.9
0.25	0.18	-	1680	1.12	0.56	270%	E	9.38	2.3	2.5	0.71	57.0%	0.0066	9.3
0.33	0.25	-	1710	1.56	0.78	310%	G	12.2	2.4	2.7	0.64	63.0%	0.017	12
0.5	0.37	-	1720	1.90	0.95	350%	F	18.3	2.3	2.7	0.69	71.0%	0.020	14
0.75	0.55	-	1710	2.70	1.35	350%	F	27.6	2.2	2.3	0.71	72.0%	0.026	18
1	0.75		1730	3.14	1.57	650	K	36.4	3.5	3.8	0.70	86.1	0.045	22
1.5	1.1		1740	4.20	2.10	840	L	54.3	4.2	4.9	0.76	86.9	0.081	33
2	1.5		1730	5.60	2.80	760	K	72.9	3.9	4.3	0.78	87.0	0.093	37
3	2.2		1770	7.68	3.84	920	L	107	3.0	4.5	0.79	90.0	0.192	62
5	3.7		1755	13.0	6.50	950	L	180	4.1	4.6	0.80	90.3	0.332	78
7.5	5.5		1770	19.5	9.75	1020	M	267	4.7	5.0	0.77	91.7	0.759	121
10	7.5		1765	26.7	13.4	960	M	357	4.7	5.0	0.77	91.7	0.831	137
15	11		1770	35.6	17.8	880	K	534	3.2	3.8	0.84	92.5	1.59	205
20	15		1775	47.6	23.8	1080	M	710	4.3	4.7	0.85	93.0	2.18	269
25	18.5		1780	60.6	30.3	1010	L	885	3.9	4.0	0.82	93.6	3.80	342
30	22		1780	69.6	34.8	880	K	1062	3.3	3.4	0.85	93.6	3.80	342



Dim up to 2.0hp (No Brake) Motors “MtR” Series

Motors & Brakemotors

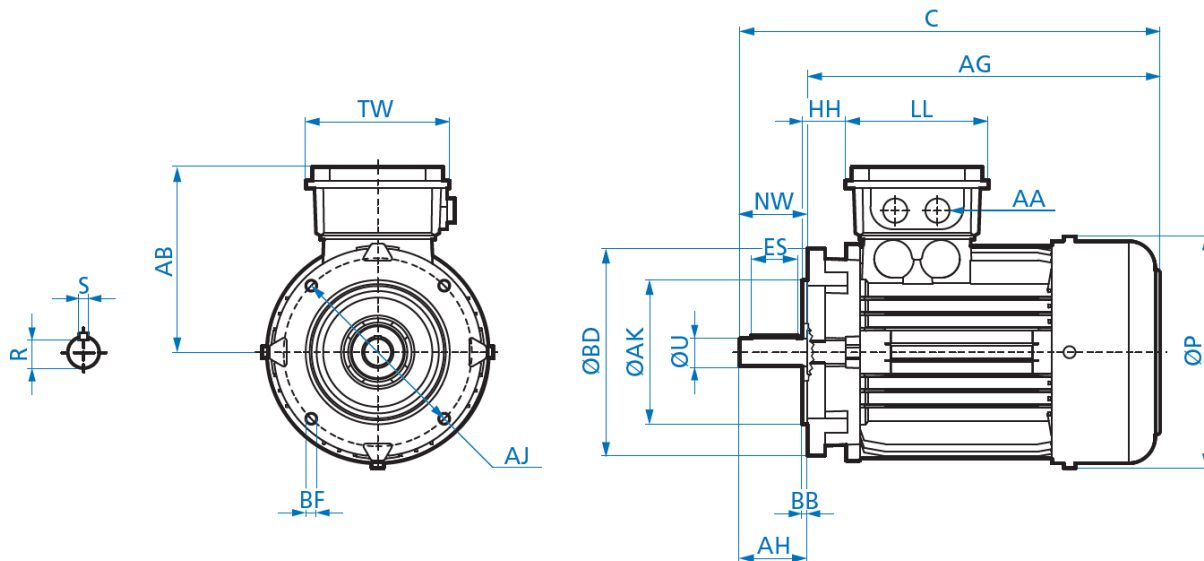

NEMA Frame	Efficiency		NEMA Frame	Overall			Flange					
	SE	PE		C	AG	P	AJ	AK	BD	BB	BF	
56C	S/L	-	56C	9.62	7.56	5.08	5.875	4.500	+0.000 -0.003	6.50	0.16	3/8-16 x 0.71
56C	S/L	-	56C	10.49	8.43	5.75	5.875	4.500	+0.000 -0.003	6.50	0.16	3/8-16 x 0.71
56C	S/L	LP	56C	11.51	9.45	6.46	5.875	4.500	+0.000 -0.003	6.50	0.16	3/8-16 x 0.87
56C	L	-	56C	11.51	9.45	6.46	5.875	4.500	+0.000 -0.003	6.50	0.16	3/8-16 x 0.87
143TC	-	LP	143TC	11.57	9.45	6.46	5.875	4.500	+0.000 -0.003	6.50	0.16	3/8-16 x 0.87
145TC	S/L	SP/LP	145TC	13.15	11.02	7.20	5.875	4.500	+0.000 -0.003	6.50	0.16	3/8-16 x 0.71

NEMA Frame	Efficiency		NEMA Frame	Shaft						Terminal Box						
	SE	PE		U	NW	AH	ES	R	S	AB	HH	LL	TW	AA (NPT)	AA (METRIC)	
56C	S/L	-	56C	0.625	+0.000 -0.0005	1.88	2.06	1.69	0.517	0.188	4.53	0.47	3.94	3.94	1/2"	M20 x1.5
56C	S/L	-	56C	0.625	+0.000 -0.0005	1.88	2.06	1.69	0.517	0.188	4.88	0.79	3.94	3.94	1/2"	M20 x1.5
56C	S/L	LP	56C	0.625	+0.000 -0.0005	1.88	2.06	1.69	0.517	0.188	5.59	1.02	4.49	4.49	3/4"	M25x1.5
56C	L	-	56C	0.625	+0.000 -0.0005	1.88	2.06	1.69	0.517	0.188	5.59	1.02	4.49	4.49	3/4"	M25x1.5
143TC	-	LP	143TC	0.875	+0.000 -0.0005	2.25	2.12	1.81	0.771	0.188	5.59	1.02	4.49	4.49	3/4"	M25x1.5
145TC	S/L	SP/LP	145TC	0.875	+0.000 -0.0005	2.25	2.12	1.81	0.771	0.188	5.79	1.18	4.49	4.49	3/4"	M25x1.5





Dim up to 3 - 30hp (No Brake) Motors "MtR" Series

Motors & Brakemotors

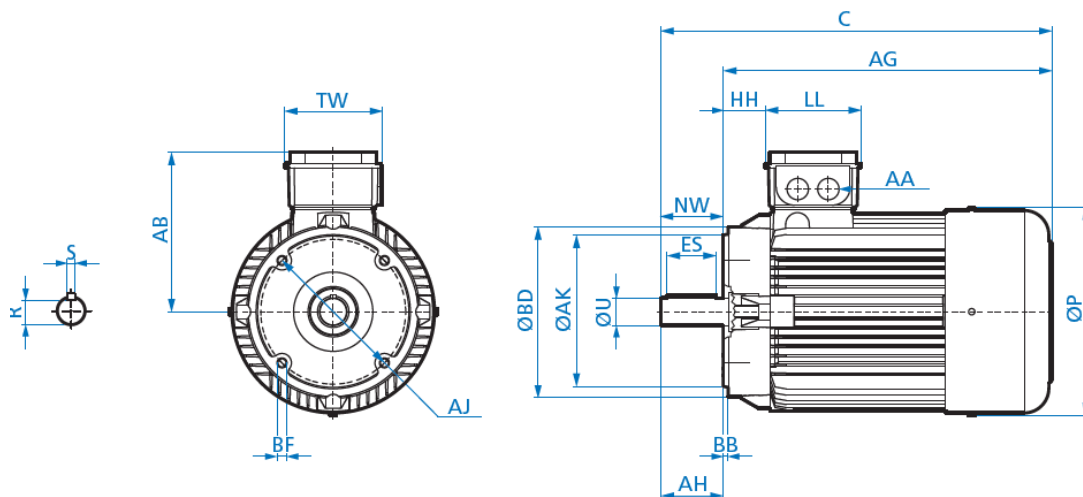

NEMA Frame	Motor Frame	Efficiency		NEMA Frame	Overall			Flange					
		SE	PE		C	AG	P	AJ	AK	BD	BB	BF	
182TC	100	L	LP	182TC	14.83	12.20	7.91	7.250	8.500	+0.000 -0.003	9.00	0.25	1/2-13x1.10
184TC	100	LA	AP	184TC	14.83	12.20	7.91	7.250	8.500	+0.000 -0.003	9.00	0.25	1/2-13x1.10
184TC	112	M	-	184TC	15.46	12.83	8.90	7.250	8.500	+0.000 -0.003	9.00	0.25	1/2-13x0.98
184TC	112	-	MP	184TC	16.44	13.82	8.90	7.250	8.500	+0.000 -0.003	9.00	0.25	1/2-13x0.98
213TC	132	S	SP	213TC	19.58	16.46	10.47	7.250	8.500	+0.000 -0.003	8.69	0.25	1/2-13x1.18
215TC	132	M	MP	215TC	19.58	16.46	10.47	7.250	8.500	+0.000 -0.003	8.69	0.25	1/2-13x1.18
254TC	160	M	MP	254TC	23.12	19.37	12.56	7.250	8.500	+0.000 -0.003	10.00	0.25	1/2-13x0.87
256TC	160	L	-	256TC	23.12	19.37	12.56	7.250	8.500	+0.000 -0.003	10.00	0.25	1/2-13x0.87
256TC	160	-	LP	256TC	24.85	21.10	12.56	7.250	8.500	+0.000 -0.003	10.00	0.25	1/2-13x0.87
284TC	180	MX	-	284TC	23.12	19.37	12.56	9.000	10.500	+0.000 -0.003	11.26	0.25	1/2-13x0.87
284TC	180	-	MP	284TC	28.79	24.42	14.25	9.000	10.500	+0.000 -0.003	11.26	0.25	1/2-13x0.87
286TC	180	LX	-	286TC	24.85	21.10	12.56	9.000	10.500	+0.000 -0.003	11.26	0.25	1/2-13x0.87
286TC	180	-	LP	286TC	28.79	24.42	14.25	9.000	10.500	+0.000 -0.003	11.26	0.25	1/2-13x0.87

NEMA Frame	Motor Frame	Efficiency		NEMA Frame	Shaft						Terminal Box						
		SE	PE		U	NW	AH	ES	R	S	AB	HH	LL	TW	AA (NPT)	AA (METRIC)	
182TC	100	L	LP	182TC	1.125	+0.000 -0.0005	2.75	2.62	2.25	0.986	0.250	6.65	1.42	4.49	4.49	1"	M32x1.5
184TC	100	LA	AP	184TC	1.125	+0.000 -0.0005	2.75	2.62	2.25	0.986	0.250	6.65	1.42	4.49	4.49	1"	M32x1.5
184TC	112	M	-	184TC	1.125	+0.000 -0.0005	2.75	2.62	2.25	0.986	0.250	7.05	1.38	4.49	4.49	1"	M32x1.5
184TC	112	-	MP	184TC	1.125	+0.000 -0.0005	2.75	2.62	2.25	0.986	0.250	7.05	1.38	4.49	4.49	1"	M32x1.5
213TC	132	S	SP	213TC	1.375	+0.000 -0.0005	3.38	3.12	3.06	1.201	0.312	8.03	2.13	4.80	4.80	1"	M32x1.5
215TC	132	M	MP	215TC	1.375	+0.000 -0.0005	3.38	3.12	3.06	1.201	0.312	8.03	2.13	4.80	4.80	1"	M32x1.5
254TC	160	M	MP	254TC	1.625	+0.000 -0.001	4.00	3.75	3.13	1.416	0.375	9.53	2.05	7.32	7.32	1"	M40x1.5
256TC	160	L	-	256TC	1.625	+0.000 -0.001	4.00	3.75	3.13	1.416	0.375	9.53	2.05	7.32	7.32	1"	M40x1.5
256TC	160	-	LP	256TC	1.625	+0.000 -0.001	4.00	3.75	3.13	1.416	0.375	9.53	2.05	7.32	7.32	1"	M40x1.5
284TC	180	MX	-	284TC	1.875	+0.000 -0.001	4.62	4.38	4.00	1.591	0.500	10.20	2.29	7.32	7.32	1"	M40x1.5
284TC	180	-	MP	284TC	1.875	+0.000 -0.001	4.62	4.38	4.00	1.591	0.500	10.20	2.29	7.32	7.32	1"	M40x1.5
286TC	180	LX	-	286TC	1.875	+0.000 -0.001	4.62	4.38	4.00	1.591	0.500	10.20	2.29	7.32	7.32	1"	M40x1.5
286TC	180	-	LP	286TC	1.875	+0.000 -0.001	4.62	4.38	4.00	1.591	0.500	10.20	2.29	7.32	7.32	1"	M40x1.5



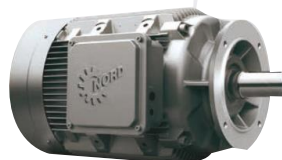

Dim up to 2.0hp (With Brake) Motors “MTR” Series

Motors & Brakemotors

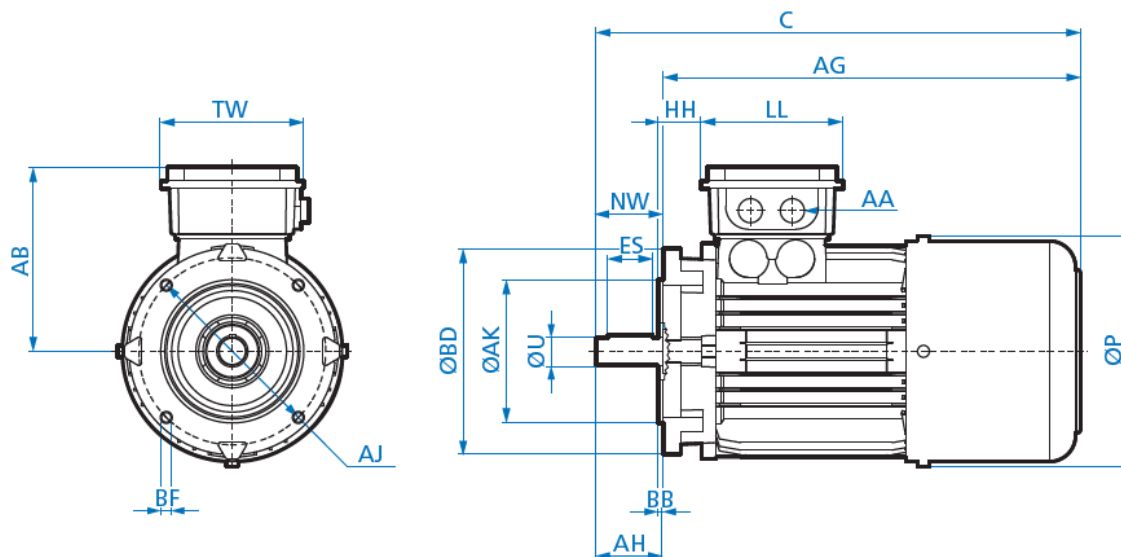

NEMA Frame	Efficiency		NEMA Frame	BRE	Overall			Flange					
	SE	PE			C	AG	P	AJ	AK	BD	BB	BF	
56C	S/L	-	56C	5	11.83	9.76	5.08	5.875	4.500	^{+0.000} _{-0.003}	6.50	0.16	3/8-16x0.71
56C	S/L	-	56C	5	12.77	10.71	5.75	5.875	4.500	^{+0.000} _{-0.003}	6.50	0.16	3/8-16x0.71
56C	S/L	LP	56C	5	14.03	11.97	6.46	5.875	4.500	^{+0.000} _{-0.003}	6.50	0.16	3/8-16x0.87
56C	L	-	56C	10	14.03	11.97	6.46	5.875	4.500	^{+0.000} _{-0.003}	6.50	0.16	3/8-16x0.87
143TC	-	LP	143TC	10	14.53	12.40	6.46	5.875	4.500	^{+0.000} _{-0.003}	6.50	0.16	3/8-16x0.87
145TC	S/L	SP/LP	145TC	20	16.73	14.61	7.20	5.875	4.500	^{+0.000} _{-0.003}	6.50	0.16	3/8-16x0.71

NEMA Frame	Efficiency		NEMA Frame	BRE	Shaft						Terminal Box						
	SE	PE			U	NW	AH	ES	R	S	AB	HH	LL	TW	AA (NPT)	AA (METRIC)	
56C	S/L	-	56C	5	0.625	^{+0.000} _{-0.0005}	1.88	2.06	1.69	0.517	0.188	4.84	0.75	5.28	3.50	1/2"	M20 x1.5
56C	S/L	-	56C	5	0.625	^{+0.000} _{-0.0005}	1.88	2.06	1.69	0.517	0.188	5.20	1.06	5.28	3.50	1/2"	M20 x1.5
56C	S/L	LP	56C	5	0.625	^{+0.000} _{-0.0005}	1.88	2.06	1.69	0.517	0.188	5.59	1.18	6.02	4.25	3/4"	M25x1.5
56C	L	-	56C	10	0.625	^{+0.000} _{-0.0005}	1.88	2.06	1.69	0.517	0.188	5.59	1.18	6.02	4.25	3/4"	M25x1.5
143TC	-	LP	143TC	10	0.875	^{+0.000} _{-0.0005}	2.25	2.12	1.81	0.771	0.188	5.59	1.18	6.02	4.25	3/4"	M25x1.5
145TC	S/L	SP/LP	145TC	20	0.875	^{+0.000} _{-0.0005}	2.25	2.12	1.81	0.771	0.188	5.79	1.34	6.02	4.25	3/4"	M25x1.5





Dim up to 3 - 30hp (With Brake) Motors "MTR" Series

Motors & Brakemotors

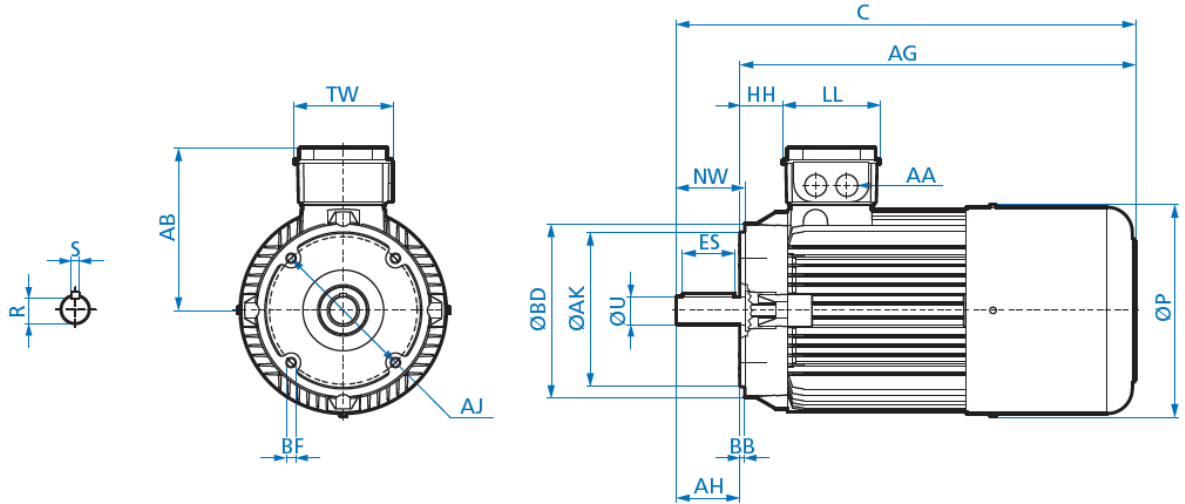

NEMA Frame	Motor Frame	Efficiency		NEMA Frame	BRE	Overall			Flange					
		SE	PE			C	AG	P	AJ	AK	BD	BB	BF	
182TC	100	L	LP	182TC	20	18.41	15.79	7.91	7.250	8.500	+0.000 -0.003	9.00	0.25	1/2-13x1.10
184TC	100	LA	AP	184TC	40	18.53	15.91	7.91	7.250	8.500	+0.000 -0.003	9.00	0.25	1/2-13x1.10
184TC	112	M	-	184TC	60	19.16	16.54	8.90	7.250	8.500	+0.000 -0.003	9.00	0.25	1/2-13x0.98
184TC	112	-	MP	184TC	60	20.66	18.03	8.90	7.250	8.500	+0.000 -0.003	9.00	0.25	1/2-13x0.98
213TC	132	S	SP	213TC	60	23.79	20.67	10.47	7.250	8.500	+0.000 -0.003	8.69	0.25	1/2-13x1.18
215TC	132	M	MP	215TC	100	23.79	20.67	10.47	7.250	8.500	+0.000 -0.003	8.69	0.25	1/2-13x1.18
254TC	160	M	MP	254TC	150	28.44	24.69	12.56	7.250	8.500	+0.000 -0.003	10.00	0.25	1/2-13x0.87
256TC	160	L	-	256TC	250	28.44	24.69	12.56	7.250	8.500	+0.000 -0.003	10.00	0.25	1/2-13x0.87
256TC	160	-	LP	256TC	250	30.17	26.42	12.56	7.250	8.500	+0.000 -0.003	10.00	0.25	1/2-13x0.87
284TC	180	MX	-	284TC	250	28.44	24.69	12.56	9.000	10.500	+0.000 -0.003	11.26	0.25	1/2-13x0.87
284TC	180	-	MP	284TC	250	34.11	29.73	14.25	9.000	10.500	+0.000 -0.003	11.26	0.25	1/2-13x0.87
286TC	180	LX	-	286TC	250	29.85	26.10	12.56	9.000	10.500	+0.000 -0.003	11.26	0.25	1/2-13x0.87
286TC	180	-	LP	286TC	250	33.79	29.42	14.25	9.000	10.500	+0.000 -0.003	11.26	0.25	1/2-13x0.87

NEMA Frame	Motor Frame	Efficiency		NEMA Frame	BRE	Shaft						Terminal Box						
		SE	PE			U	NW	AH	ES	R	S	AB	HH	LL	TW	AA (NPT)	AA (METRIC)	
182TC	100	L	LP	182TC	20	1.125	+0.000 -0.0005	2.75	2.62	2.25	0.986	0.250	6.77	1.57	6.02	4.25	1"	M32x1.5
184TC	100	LA	AP	184TC	40	1.125	+0.000 -0.0005	2.75	2.62	2.25	0.986	0.250	6.77	1.57	6.02	4.25	1"	M32x1.5
184TC	112	M	-	184TC	60	1.125	+0.000 -0.0005	2.75	2.62	2.25	0.986	0.250	7.17	1.54	6.02	4.25	1"	M32x1.5
184TC	112	-	MP	184TC	60	1.125	+0.000 -0.0005	2.75	2.62	2.25	0.986	0.250	7.17	1.54	6.02	4.25	1"	M32x1.5
213TC	132	S	SP	213TC	60	1.375	+0.000 -0.0005	3.38	3.12	3.06	1.201	0.312	7.91	1.85	7.28	5.47	1"	M32x1.5
215TC	132	M	MP	215TC	100	1.375	+0.000 -0.0005	3.38	3.12	3.06	1.201	0.312	7.91	1.85	7.28	5.47	1"	M32x1.5
254TC	160	M	MP	254TC	150	1.625	+0.000 -0.001	4.00	3.75	3.13	1.416	0.375	9.53	2.05	7.32	7.32	1"	M40x1.5
256TC	160	L	-	256TC	250	1.625	+0.000 -0.001	4.00	3.75	3.13	1.416	0.375	9.53	2.05	7.32	7.32	1"	M40x1.5
256TC	160	-	LP	256TC	250	1.625	+0.000 -0.001	4.00	3.75	3.13	1.416	0.375	9.53	2.05	7.32	7.32	1"	M40x1.5
284TC	180	MX	-	284TC	250	1.875	+0.000 -0.001	4.62	4.38	4.00	1.591	0.500	9.53	2.29	7.32	7.32	1"	M40x1.5
284TC	180	-	MP	284TC	250	1.875	+0.000 -0.001	4.62	4.38	4.00	1.591	0.500	9.53	2.37	7.32	7.32	1"	M40x1.5
286TC	180	LX	-	286TC	250	1.875	+0.000 -0.001	4.62	4.38	4.00	1.591	0.500	9.53	2.29	7.32	7.32	1"	M40x1.5
286TC	180	-	LP	286TC	250	1.875	+0.000 -0.001	4.62	4.38	4.00	1.591	0.500	10.20	2.37	7.32	7.32	1"	M40x1.5





SECTION 1: APPLICABILITY

1.1 These terms & conditions (the "Terms and Conditions") of sale are applicable to all quotations for the sale or orders for the purchase of all equipment or goods (the "Products") made by or for Fangtooth Inc 11970 Mayfield St. Livonia MI 48150 ("Company").

1.2 Unless otherwise agreed, written quotations are valid for 30 days from the date of quotation. All price lists and discounts are subject to change without notice.

1.3 All orders placed by the Buyer are subject to written acceptance by the Company. No contract between Buyer and Company shall exist prior to the time of such acceptance by the Company.

1.4 These Terms & Conditions supersede all prior written terms, understandings, purchase orders, assurances and offers. Company shall not be deemed to have waived these Terms & Conditions if it fails to object to the conditions appearing in or attached to a purchase order issued by Buyer. Buyer's acceptance of the Products or services furnished by the Company shall constitute its acceptance of these Terms & Conditions.

SECTION 2: PRICE & SHIPPING DATES

2.1 All orders must be bona fide commitments showing a complete description of equipment, quantity, price & shipping dates required by the Buyer.

2.2 Timely performance by Company is contingent upon Buyer supplying to Company, when applicable, all required technical information and data, including drawing approvals, and all required commercial documentation. Shipping dates are subject to final confirmation or change by Company and are based on prompt receipt of all necessary information regarding the order. Unless otherwise indicated, all delivery dates specified by the Company are estimated time frames and time is not of the essence in Company's performance of the sale of the Products.

2.3 If shipment is delayed for thirty (30) days or more from the delivery date accepted by the Company for reasons attributable to the Buyer and provided that the Buyer shall have no other liability to the Company in respect of such delay, the reasonable direct costs of putting the Products into storage at a facility off-site of Company's premises until such times as they are shipped (or delivered) shall be the to the Buyer's account and at Buyer's sole risk.

SECTION 3: PAYMENT

Terms of payment are net 30 days from the date of invoice unless otherwise agreed in writing. Late payments may be subject to interest on the unpaid balance at the greater of 2% per month or the maximum rate permitted by law. No deductions or set-offs are to be made by Buyer from amounts due unless specifically authorized by the Company in writing. In the judgment of the Company, the financial condition of Buyer at any time does not justify continuance of production or shipment on the terms of payment specified, the Company may require full or partial payment in advance.

SECTION 4: TAXES

The Company's prices do not include sales, use, excise taxes, tariffs, duties or value added or similar taxes or fees. The Company will add such taxes or fees to the invoice unless the Buyer provides Company with tax-exempt certificate acceptable to the applicable taxing authorities or arranges payment of such taxes or fees directly by the Buyer.

SECTION 5: WARRANTY

5.1 NEW PRODUCT – Company warrants the Products shall be free of defects in material and workmanship and meet the Product specifications for a period from the date of shipment as specified below.

5.1.a FANGTOOTH MAX straddle mounted pinion systems – 3 years.

5.1.b FANGTOOTH OPEN cantilevered pinion systems – 2 years.

5.1.c FANGTOOTH Any products not specified as standard including any units with non-standard coatings for corrosion claims – 1 year.

5.1.d FANGBOT integrated systems – FANGTOOTH MAX integrated into larger systems will carry the full 3 year warranty. FANGTOOTH OPEN integrated into larger systems will carry the full 2 year warranty. Custom (non-standard) engineered products within the larger systems or any other non-standard FANGTOOTH products will be warranties for 18 months.

5.2 Notwithstanding the warranty periods listed above, the warranty on normal wear items such as oil seals is limited to one year. The warranties of gearboxes, motors, brakes, couplings, linear rail, linear bearings, gear rack and pinion and all other add on items shall be the warranties provided by, and shall be the responsibility of, the original equipment manufacturer. The Company is not responsible for and does not warrant (a) equipment, components and/or material furnished by the Buyer; (b) the sufficiency of functionality of any design specifications furnished by the Buyer; nor shall Company be liable for defects or damages arising from the foregoing. Notwithstanding any other provision in these Terms and Conditions, none of the warranties given by the Company shall apply to products manufactured by others and sold by the Company. Buyer will at its own expense arrange for any dismantling and reassembly of any goods and equipment and the provision of all equipment (including without limitation lifting equipment and crane-age) to the extent that this is necessary to remedy the defect or facilitate re-performance of service.

Unless otherwise agreed, necessary transport of the Products and/or parts thereo to and from Company in connection with the remedying of defects will be at the risk and expense of the Buyer. Buyer will follow Company's instructions regarding such transport.

Unless otherwise agreed, Buyer will bear any additional costs which Company incurs as a result of the Products being located in a place other than the place of delivery.

Defective parts which have been replaced will be made available to Company and will be its property.

5.3 Any claims under this warranty must be made in writing to the Company at the address set forth above (or by email) within thirty (30) days of the discovery thereof. The

Company's obligation under this warranty shall be limited to the repair or replacement, at the Company's option, of the Product, or any part thereof, when the Company has determined the Product is not warranted; any Product or parts repaired or replaced pursuant to the warranty will be warranted for the remainder of the original warranty period. The Company shall not be responsible for any claims which the Company determines are due to improper installation, operation above rated capacity, exceeds L10 life cycles, operation at extreme conditions, normal wear and tear, accident, or because the Product has been used, adjusted, altered, handled, maintained, repaired or stored other than as directed by the Company.

5.4 This warranty shall not apply in the event of defects caused by: (i) physical abuse of the Products or any component, or acts of vandalism by any persons other than Company; (ii) alterations, modifications, additions, or repairs made during the applicable warranty period by anyone other than Company, and its authorized employees, agents or subcontractors; (iii) accidents or damage resulting from fire, water, wind, hail, lightning, electrical surge or failure, earthquake, theft or similar causes not caused by the sole negligence of Company; (iv) damage as a result of corrosion or other damage caused by Buyer's failure to protect and maintain the Products in accordance with Company's written instructions and warnings; or (v) design specifications furnished by Buyer.

5.5 Buyer shall not rely upon Company's skill or judgement or furnish Products for any particular purpose beyond the specific express warranties provided herein. Buyer has the responsibility to determine whether the Products and specifications are fit for buyer's intended purpose. Company does not warrant the Products will comply with the requirements or any safety code or regulations, or with any environmental or other law or regulation. Buyer is responsible for the safe and lawful operation and use of the Products.

5.9 THE FOREGOING WARRANTIES ARE THE SOLE WARRANTIES PROVIDED BY COMPANY FOR THE PRODUCTS AND ARE IN LIEU OF ALL OTHER WARRANTIES, EXPRESS OR IMPLIED, ALL OF WHICH ARE HEREBY DISCLAIMED AND EXCLUDED BY MERCHANTABILITY OR FITNESS FOR A PARTICULAR PURPOSE OR USE. BUYER AGREES THAT ITS SOLE AND EXCLUSIVE REMEDY AGAINST COMPANY WILL BE LIMITED TO THE REPAIR AND REPLACEMENT OF NONCONFORMING OR DEFECTIVE PRODUCTS PROVIDED COMPANY IS PROMPTLY NOTIFIED IN WRITING OF ANY DEFECT. THIS EXCLUSIVE REMEDY WILL NOT BE DEEMED TO HAVE FAILED OF ITS ESSENTIAL PURPOSE SO LONG AS COMPANY IS WILLING TO REPAIR OR REPLACE THE NONCONFORMING OR DEFECTIVE PRODUCTS.

SECTION 6: OWNERSHIP OF INTELLECTUAL PROPERTY

Company retains ownership and all rights to its intellectual property. Buyer shall have no rights to Company's intellectual property. Any intellectual property developed by Company and arising in connection with the supply of Products hereunder shall be deemed property of Company, and Company shall have exclusive rights to the use and ownership of such intellectual property.

SECTION 7: THIRD PARTY INTELLECTUAL PROPERTY CLAIMS

Company shall pay costs and damages finally awarded in any suit against Buyer by a third party to the extent based upon a finding that the design or construction of the Products as furnished infringes a patent or other third party intellectual property rights (except infringement occurring as a result of incorporating a design or modification at Buyer's request), provided that Buyer promptly notifies Company of any charge of infringement, and Company is given the right at its expense to settle such charge and to defend or control the defense of any suit based upon such charge. Company shall have no obligation hereunder with respect to claims, suits or proceedings, resulting from or related to, in whole or in part, (i) the use of software or software documentation, (ii) compliance with Buyer's specifications, (iii) the combination with other products, or modification of, the Products after delivery by Company, or (iv) the use of the Products, or any part thereof, in the practice of a process. THIS SECTION SETS FORTH COMPANY'S ENTIRE LIABILITY WITH RESPECT TO PATENTS OR OTHER INFRINGEMENTS OF INTELLECTUAL PROPERTY.

SECTION 8: RETURN OF PRODUCTS

In the event that the Buyer does not accept the Products, the Buyer must apply for authorization from the Company before returning the Products to the Company for credit. The Company will advise the Buyer of the credit to be allowed and necessary restocking charges on the unused material, subject to the Company's inspection and acceptance when received. No material should be returned to the Company except upon receipt of written authorization. In addition to the usual restocking charges, the Buyer must pay the actual transportation expense of the Company, plus all return transportation costs. Motors and specially designed parts will not be accepted for return or credit.

SECTION 9: DELIVERY, TITLE AND RISK OF LOSS

The Products will be delivered Ex Works – Fangtooth Inc's facility (in accordance with Incoterms 2010) unless otherwise agreed in writing by Company. The Buyer will be responsible for making all shipping arrangements, and Buyer will provide sufficient notice and details of such arrangements to allow Company to prepare the Products for delivery. Title and risk of loss will remain with Company and not pass to Buyer until delivery to the Incoterm delivery point.

SECTION 10: FORCE MAJEURE

Company will not be deemed to be in default or otherwise responsible for delays or failures in performance resulting from acts of God: acts of war, or civil disturbance, terrorism, epidemics, governmental action or inaction, fires, floods, earthquakes, tornadoes, or other events beyond Company's reasonable control (a "Force majeure Event"). A Force Majeure Event affecting Company's vendors shall also be deemed as a Force Majeure Event for the Company, provided that the Company shall use commercially reasonable efforts to mitigate any delays caused by its vendor's Force Majeure situation. Company shall in such instances give notice of the non-performance (including its anticipated duration) to the Customer promptly after becoming aware that it has occurred or will occur. In no event shall lack of finances or ability to pay as a result of the financial condition of either party be considered a Force Majeure Event.

SECTION 11: CANCELLATION

Upon written acceptance of an order by the Company, Buyer may not cancel or terminate for convenience, or direct suspension of manufacture, except with Company's written consent and then only upon terms that will compensate Company for its engineering, fabrication and purchasing charges and any other costs relating to such cancellation, termination, or suspension, plus a reasonable amount for profit and overhead.

SECTION 12: ETHICAL BUSINESS PRACTICES

Company requires manufacturing and business practices that are compliant with all applicable laws and regulations, including, the need to conduct all transactions in compliance with ethical business practices. Both the Company and the Buyer agree that neither of them nor their employees, agents, representatives, or other intermediaries will engage in any activity that may be construed to be in violation of their respective codes of ethical business practices or applicable law. Buyer acknowledges and agrees that it shall not, in regards to the sale or resale of the Company's products, make any payment or transfer of value to any third party (including through any or multiple intermediaries) that would cause either the Buyer, Company or any of Company's affiliates to violate either the U.S. Foreign Corrupt Practices Act or any other applicable anti-corruption laws. Buyer shall indemnify and hold Company and Company's affiliates harmless in the even of any breach of this paragraph by buyer or any of its intermediaries.

SECTION 13: LIMITATION OF LIABILITY

NEITHER COMPANY AND ITS AFFILIATES AND THEIR RESPECTIVE OFFICERS, DIRECTORS, EMPLOYEES, AGENTS, INSURERS AND ATTORNEYS SHALL BE LIABLE, WHETHER IN CONTRACT, WARRANTY, FAILURE OF A REMEDY TO ACHIEVE ITS INTENDED OR ESSENTIAL PURPOSES, TORT (INCLUDING LOSS OF USE, REVENUE OR PROFIT, OR FOR COSTS OF CAPITAL OR OF SUBSTITUTE USE OR PERFORMANCE, OR FOR INDIRECT, SPECIAL, LIQUIDATED, INCIDENTAL OR CONSEQUENTIAL DAMAGES, OR FOR ANY OTHER LOSS OR COST OF SIMILAR TYPE, OR FOR OTHER CLAIMS BY BUYER FOR ANY DAMAGES OR LOSSES. COMPANY'S MAXIMUM LIABILITY FOR ALL CLAIMS AND LOSSES ARISING OUT OF THE MANUFACTURE OR SALE OF THE PRODUCTS SHALL BE THE PRICE CONFIRMED BY THE COMPANY RELATING TO THE INDIVIDUAL SALE TRANSACTION WITH THE BUYER. BUYER AND COMPANY AGREE THAT THE EXCLUSIONS AND LIMITATIONS SET FORTH IN THIS SECTION ARE SEPARATE AND INDEPENDENT FROM ANY REMEDIES WHICH BUYER MAY HAVE HEREUNDER AND SHALL BE GIVEN FULL FORCE AND EFFECT WHETHER OR NOT ANY OR ALL SUCH REMEDIES SHALL BE DEEMED TO HAVE FAILED OF THEIR ESSENTIAL PURPOSE.

SECTION 14: GOVERNING LAW

The terms of the sales of the Products shall be governed and controlled in all respects by the laws of the State of Michigan and all disputes, including interpretation, enforceability, validity, and construction, shall be determined under the law of the State of Michigan without regard to any conflict of law provisions. Any dispute arising between the parties will be finally resolved in the state or federal courts of Michigan. Each party consents to personal jurisdiction in the state and federal courts of the State of Michigan for any all matters related to or arising out of the sale, attempted sale, delivery, warranty, maintenance or use of the Products, and agrees that personal jurisdiction in any such court will be deemed proper. Buyer shall be liable to Company for any attorney fees and costs incurred by Company in enforcing any of its rights hereunder.

SECTION 15: STATUTE OF LIMITATIONS

To the extent permitted by applicable law, any lawsuit for breach of contract, including breach of warranty, arising out of the transactions covered by this Purchase Order, must be commenced not later than twelve (12) months from the date the cause of action accrued.

SECTION 16: CHANGES IN LAWS AND REGULATIONS

Company's prices and timely performance are based on all applicable laws, rules, regulations, orders, codes, standards or requirements of governmental authorities effective on the date of Company's proposal. Any applicable change to the forgoing shall entitle Company to an equitable adjustment in the prices and time of performance.

SECTION 17: COMPLIANCE WITH EXPORT LAWS AND REGULATIONS

Certain Products manufactured by Company, as well as technical data related thereto, may be subject to export licensing controls under the U.S. Export Administration Regulations and/or the U.S. International Traffic in Arms Regulations, which require licensing for and/or prohibit the export or diversion of the Company's products to certain countries. If Buyer is responsible for obtaining export approvals. Buyer warrants that it will not assist or participate in any export of the Company's products or related technical data without first obtaining the required export license and will not knowingly assist or participate in any such diversion or other violation of applicable U.S. laws and regulations. If Company is responsible for obtaining export approvals, Buyer shall assist the Company, as necessary, in obtaining such approvals. Buyer shall indemnify and hold the Company and its affiliates harmless from any losses or claims arising out of or related to Buyer's failure to comply with applicable export control laws and regulations.

SECTION 18: COMPLIANCE WITH LAWS

Buyer agrees to comply with all applicable local, state, Federal and Foreign laws, orders, directives, and regulations at any time in effect, including, but not limited to, those found in 41 CFR 60 requiring equal opportunity and affirmative action without regard to race, color, religion, sex, national origin, presence of disability or status as a special disabled veteran or Vietnam era veteran, which specifically incorporated herein by reference. If Buyer fails to comply with the provisions of this paragraph, Company may, by written notice to Buyer, terminate any Order for Buyer's default in addition to exercising any other rights or remedies provided by law.

SECTION 19: RELATIONSHIP OF THE PARTIES

Buyer and Company are independent contractors, and nothing in the contract makes either party the agent or legal representative of the other party for any purpose. Neither party has authority to assume or to create any obligation on behalf of the other party.

SECTION 20: WAIVER

The failure of Company to enforce any right or remedy provided in contract or by law on a particular occasion will not be deemed a waiver of that right or remedy on a subsequent occasion or a waiver of any other right or remedy.

SECTION 21: SEVERABILITY

A finding that any provision in these Terms & Conditions or an accepted purchase order is invalid or unenforceable in any jurisdiction will not affect the validity or enforceability of any other provision of these Terms & Conditions or an accepted purchase order or the validity or enforceability of that provision in any other jurisdiction.

SECTION 22: ASSIGNMENT and DELEGATION

No right or interest in the sale of Products hereunder shall be assigned by the Buyer without written permission of the Company. No delegation of any obligation owed, or the performance of any obligation by the Buyer, shall be made without the written permission of the Company. Any attempted assignment of delegation shall be wholly void and totally ineffective for all purposes unless made in conformity with this section. Company shall have the right to assign its obligations to any affiliate of the Company or any successor to substantially all the business or assets of the Company.

SECTION 23: THIRD PARTY RIGHTS

Notwithstanding any provision of law, no third party (including Buyer's customer) shall have the right to enforce these Terms & Conditions or any other contractual rights against Company or its affiliates.

SECTION 24: HEADINGS

The headings of the various paragraphs of these Terms & Conditions have been inserted for convenient reference only and shall not to any extent have the effect of modifying, amending, or changing the expressed terms and provisions hereof.

SECTION 25: ENTIRE AGREEMENT

These Terms & Conditions, including any attachments hereto, constitutes the entire understanding and agreement between the parties and supersedes any prior oral or written agreements with respect to the subject matter hereof. No course of prior dealings between the and the Buyer, and no usage of the trade shall be relevant to supplement or explain and term used herein. Acceptance or acquiescence in a course of performance rendered hereunder shall not be relevant to determine the meaning of these Terms & Conditions even though the accepting or acquiescing party has knowledge of the performance and opportunity for objection. Whenever a term defined by the Uniform Commercial Code is used herein, the definition contained in the Uniform Commercial Code shall control



Neptune/Triton Jack

fang TOOTH

Featured Product:

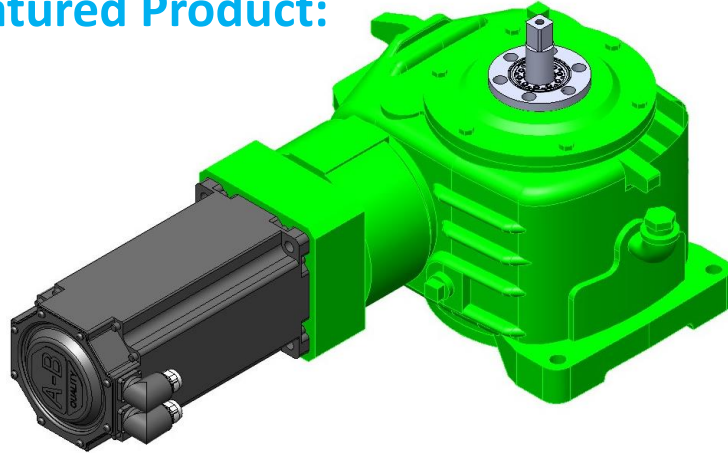

16,681
Pound Max
Lifting
Capacity



Fangtooth Inc.
11790 Mayfield St
Livonia, MI 48150
Ph 248-798-4877

fang TOOTH

AUTOMATION IDEAS
WITH TEETH

ACTUATORS



GEAR
BOXES

ROLLED
BALLSCREWS



HIGH FORCE
LIFTING JACKS
& GUIDED RACK



MULTI
AXIS
SYSTEMS



CUSTOM
ENGINEERED
PRODUCTS